

---

# TRANSDUCERS

# TRANSDUCERS

---

- Different physical signals are transformed in electrical ones.
- Based on physical principles (i. e. a potentiometer measures the distance from a reference point through the variation of the resistance).
- It is important to establish what physical magnitude is measured and what electrical signal is provided.
- Order of magnitude of the physical quantity measured (if  $\Delta T = 100 \text{ }^\circ\text{C} \Rightarrow$  thermocouple, for light temperature variations  $\Rightarrow$  thermoresistors).
- Amplitude of the emitted electronic signal (amplification, rectifying, ...).
- Data-sheet
- Resolution (ex. potentiometer) and granularity (or sensibility)

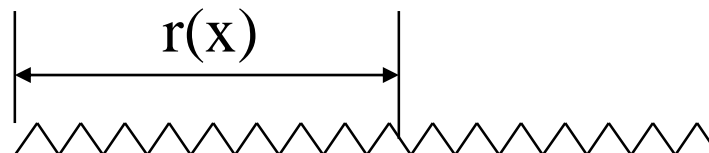

# TRANSDUCERS CHARACTERISTICS

## STATIC

- **I/O TRANSFER FUNCTION:** linear if possible
- **SENSIBILITY** ( $\Delta GE / \Delta GF$ ) (ideally constant, otherwise compensation)
- **WORKING THRESHOLD** (ex. pressure transducer)
- **RESOLUTION** (minimum variation of the physical magnitude to be evaluated)
- **HYSTERESIS** (the sensor “remembers” its own behavior: it depends also on the full scale value)
- **ENVIRONMENTAL CONDITIONS** (temperature, pressure, values range)

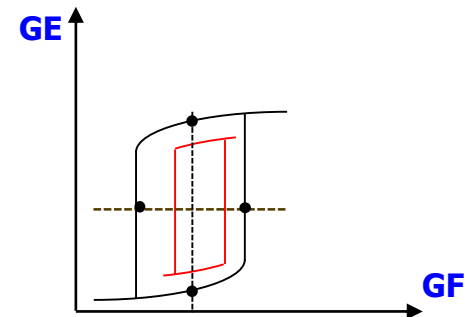
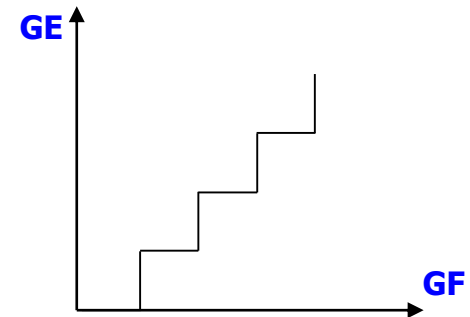
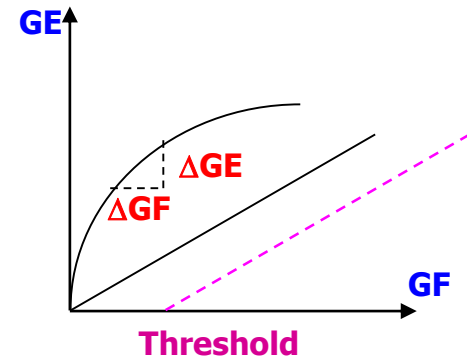

# TRANSDUCERS CHARACTERISTICS

## DYNAMIC

- The capability of the transducer to couple with the process time constant
- **TRANSFER FUNCTION AND CUTOFF FREQUENCY**
  - stability
  - promptness (answer velocity ex. microwave oven and thermocouple)
- **RELIABILITY/AFFORDABILITY:**
  - work in specified conditions
  - graceful degradation
  - reversibility in case of overload

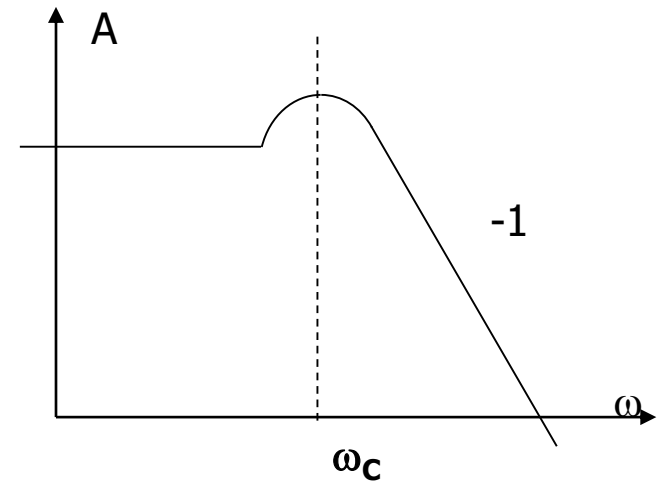

# LINEAR POSITION TRANSDUCERS

---

They are sensible to the object coordinates although it is steady (parametric)

We will distinguish:

- **LINEAR POSITION TRANSDUCERS WITH RESISTIVE OR CAPACITIVE VARIATION** (wire wound potentiometer, electro-optical, capacitive)
- **LINEAR POSITION TRANSDUCERS WITH MAGNETIC COUPLE VARIATION** (differential, variable reluctance)
- **ANGULAR POSITION TRANSDUCERS** (potentiometer, synchro, absolute and incremental encoders)

# WIREWOUND POTENTIOMETER

It is sensible to the coordinate of an object although that object is stationary. The transducer will be parametric that is it will provide the variation of its internal resistance vs the variation of the cursor position.

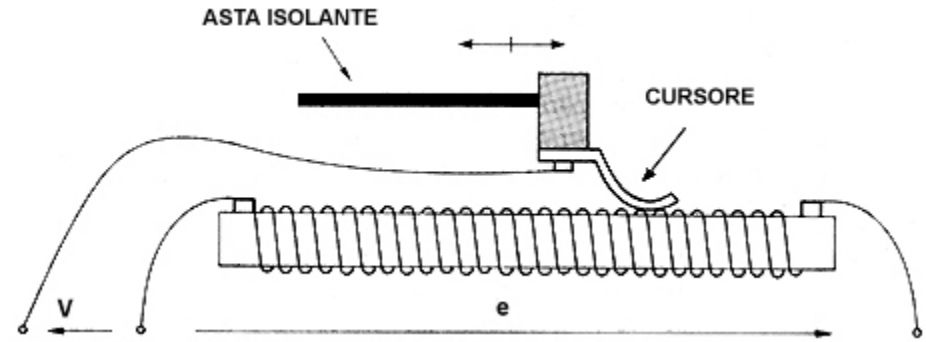
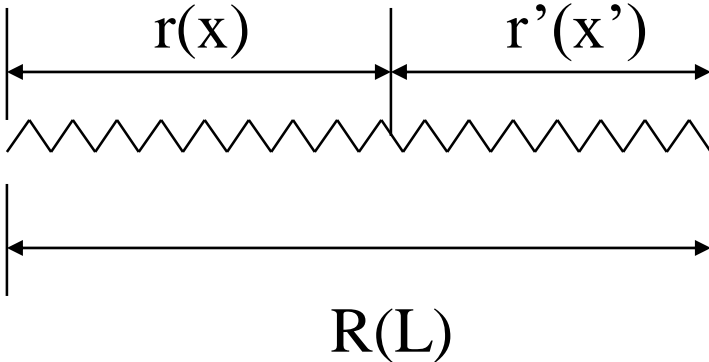

$$r(x) = \frac{x}{L} R \quad r'(x) = \frac{x'}{L} R = \left(1 - \frac{x}{L}\right) R$$

If the potentiometer is crossed by a constant current the measurement becomes a voltage measure

$$V = \frac{r E}{r + r'} = \frac{\frac{xR}{L} E}{R} = \frac{x}{L} E \Rightarrow V \propto x$$

# WIREWOUND POTENTIOMETER: Problems

## • SENSIBILITY:

a) The resistance does not change with continuity but with *steps*. A *carbon-resistance* could be used, but aging, abrasions and temperature can affect the measurements;

b) The output impedance is not constant and in particular is maximum in the center ( $R/4$ ). A decoupling buffer must be employed;

c) Is the output depending on the temperature? No, if the variation is homogeneous along the transducer.

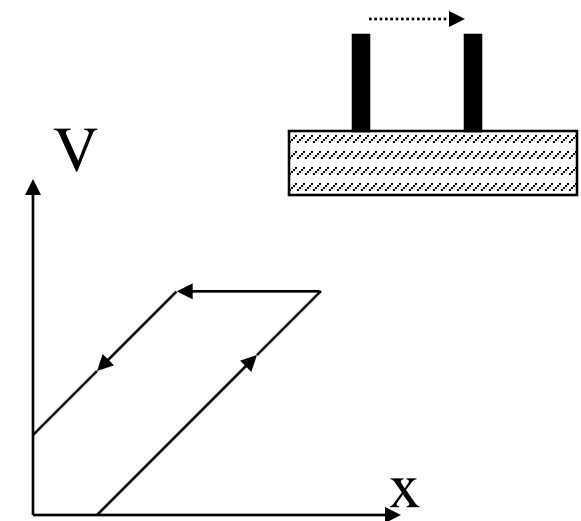
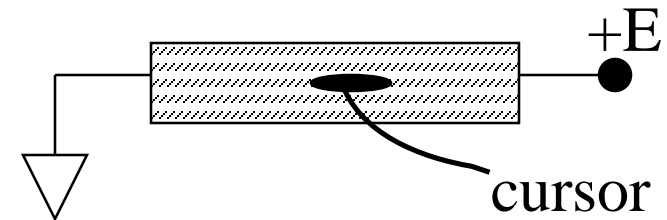

## • LOAD EFFECTS

a) The friction between the cursor and the surface creates a threshold below which the transducer does not change its output;

b) This together with the cursor elasticity could introduce a possible hysteresis in the transfer function

# ELECTRO-OPTICAL TRANSDUCER

The connection of the cursor and the potentiometer is carried out by means of photo-electric material.

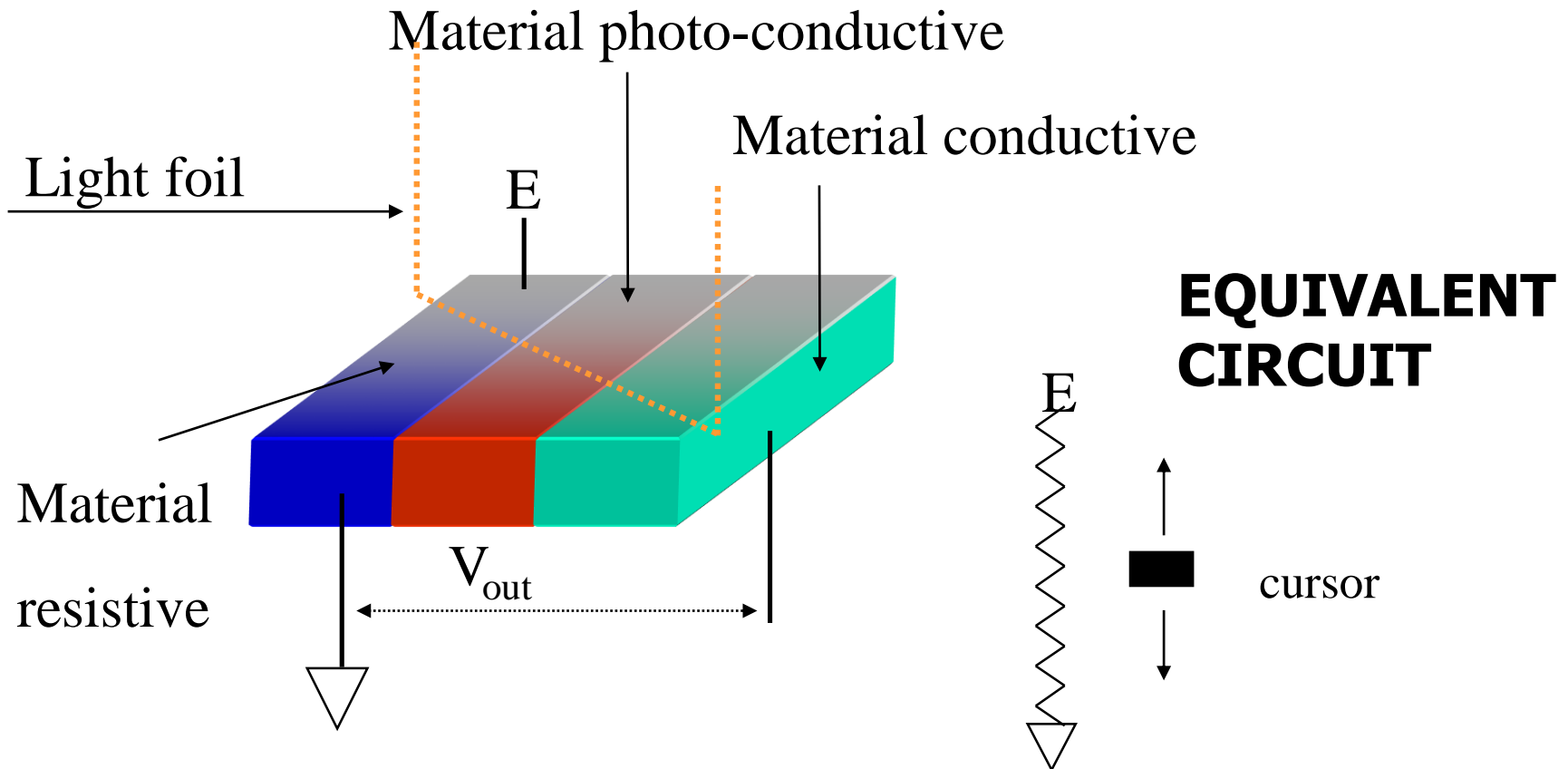



# ELECTRO-OPTICAL TRANSDUCER

---

- **The connection resistance between conductive and not conductive materials is due to the photo-conductive material  $\Rightarrow$  buffer.**
- **Pros: no mechanical contacts (no friction, more long life duration)**
- **Cons: a good darkness is required that requires particular careful construction (costs and size).**

How the light foil is carried out

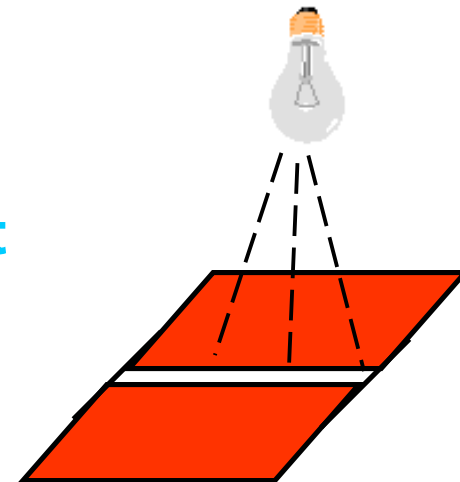

# CAPACITIVE POTENTIOMETER

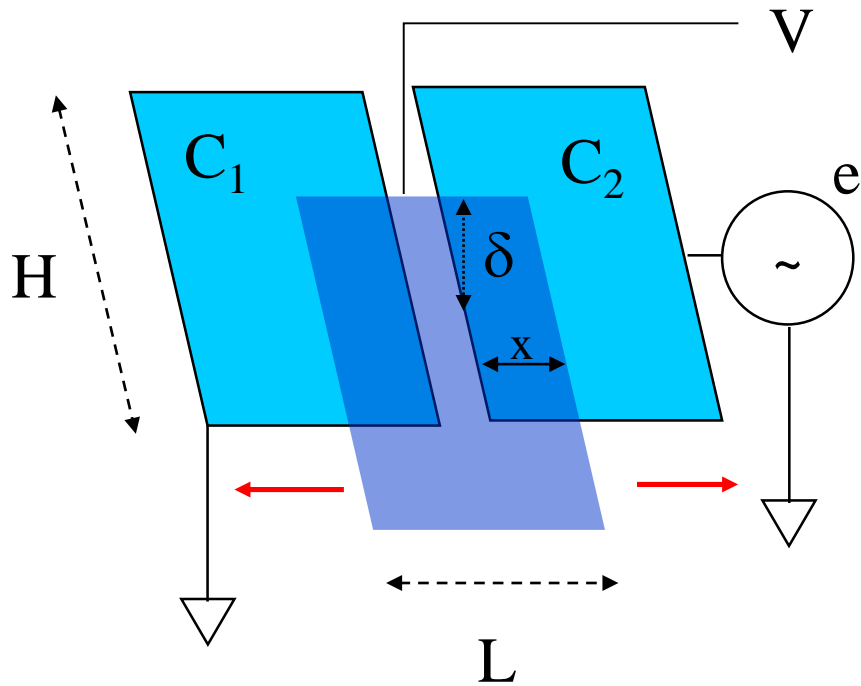

Mobile armor overlaid to (or by) two fixed ones

$$C_1 = \frac{H(L-x)}{\delta} \epsilon_0 \quad C_2 = \frac{Hx}{\delta} \epsilon_0$$

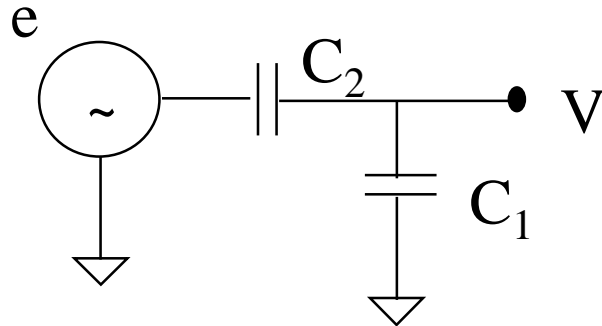

$$V = \frac{\frac{1}{sC_1}}{\frac{1}{sC_1} + \frac{1}{sC_2}} e = \frac{C_2}{C_1 + C_2} e = \frac{\frac{Hx}{\delta} \epsilon_0}{\frac{Hx}{\delta} \epsilon_0 + \frac{H(L-x)}{\delta} \epsilon_0} e = \frac{x}{L} e$$

# CAPACITIVE POTENTIOMETER

- **Output impedance**

$$Z_o = \frac{1}{s[C_1 + C_2]} = \frac{\delta}{sHL\epsilon_0}$$

High due to  $\epsilon_0$  ( $8.85 \times 10^{-12}$  F/m).

To raise up the working frequency complicates the measurement since causes rectifying problems.

- **Border effects**

The closer the armor are, the flatter will be the curve below and above a certain distance.

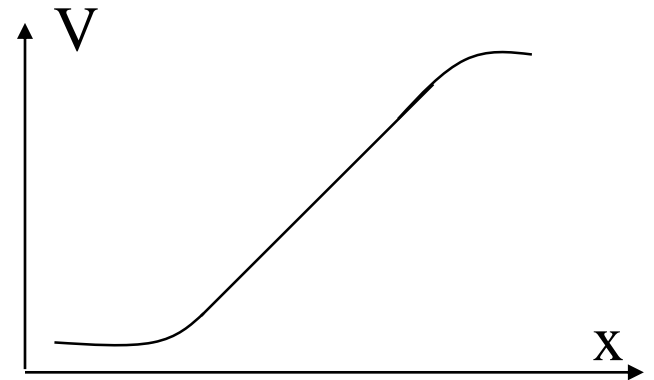

- **No contacts so longer average life**

# MAGNETIC COUPLING VARIATION TRANSDUCER

## DIFFERENTIAL TRANSDUCER

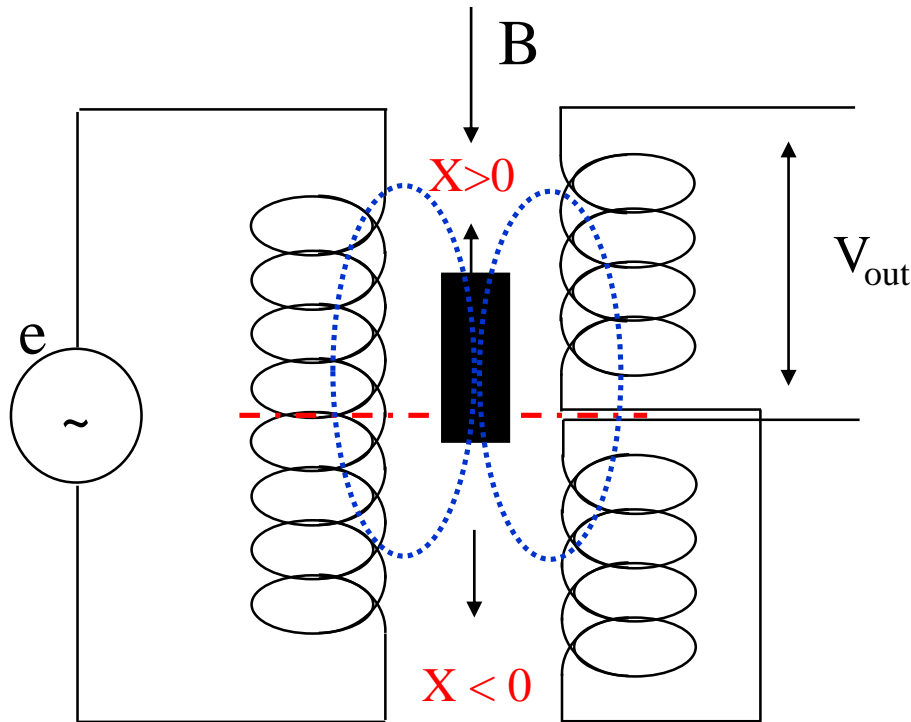

A primary circuit and two secondary ones with a ferromagnetic mobile nucleus, whose position is the variable to be measured.

The secondary circuits are serially connected but not in phase (opposed)  
 $V_{\text{out}} = V_1 - V_2$

The movement direction is deduced according to  $V_{\text{out}}$  in phase or not with  $e$

$\Phi(B)$  = flux of  $B$  reasonably present ONLY where the nucleus is located (this is an approximation).

# DIFFERENTIAL TRANSDUCER

---

- For every coil of a reel the flux of B is:

$$\Phi = BS \quad (\text{S section of a coil and also of the nucleus})$$

- The flux chained to each coil is related to the n° of coils crossed by the magnetic field force lines ( $N_1$  are relative to the first reel in the secondary circuit and  $N_2$  in the second one):

$$\Phi_1 = \Phi N_1 \quad \Phi_2 = \Phi N_2$$

- Due to the Faraday-Neumann law a flux variation induces an electromotive (*emf*) force in the coil crossed by the force lines of the magnetic field.

$$emf = -\frac{d\varphi}{dt} \quad \text{thus } V_1 = -s\Phi N_1 \text{ and } V_2 = -s\Phi N_2$$

- Also the vice-versa is valid: a time-variable *efm* causes a magnetic field flux whose derivative time the n° of crossed coils is equal to the *efm* itself

# DIFFERENTIAL TRANSDUCER

$$e = -N_p s \Phi = -n_p L s \Phi$$

$n_p$  = density of coils in the primary circuit in front of the nucleus.

$$N_1 = n_s \left[ \frac{L}{2} + x \right] \quad e \quad N_2 = n_s \left[ \frac{L}{2} - x \right]$$

$n_s$  = density of coils on the secondary circuit in front of the nucleus whose height is  $L$ .

By replacing we obtain

$$V = V_1 - V_2 = \frac{2n_s}{n_p} \frac{x}{L} e$$

This is still a linear relationship between the measured voltage and the displacement of the nucleus vs the reference position (in this sense the transducer is differential). Often, moreover,  $n_s = n_p$ .

The circuit should be used at low frequencies since the output impedance is low in this case ( $j\omega Z_L$ ).

# VARIABLE INDUCTANCE TRANSDUCER

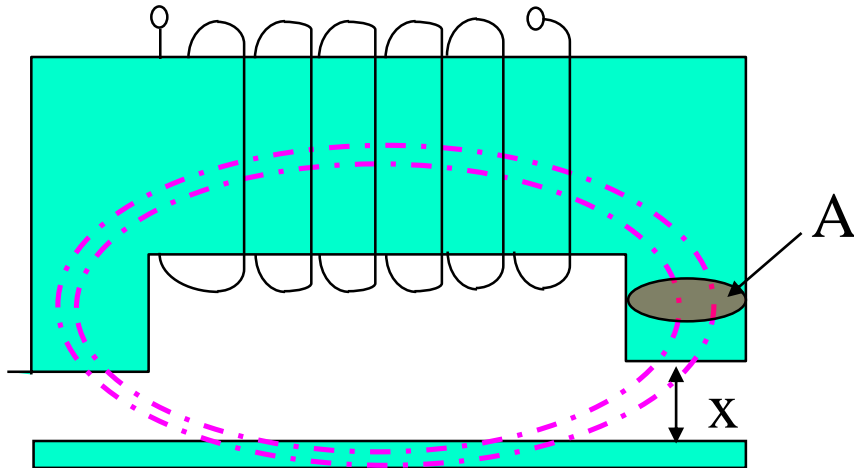

A ferromagnetic nucleus with 'C' shape is equipped with a mobile ferromagnetic foil in front of it.

The closer the foil, the greater is the flux of the magnetic field, and greater is the inductance effect in the circuit (see after).

$$R = \text{magnetic reluctance} = \frac{\text{magnetomotive force}}{\text{flux of } B} = \frac{nI}{\Phi_B}$$

If the air area between nucleus and foil is small we can consider the system as ferromagnetic circuit into which the reluctance plays a role similar to the role of a resistor in electric circuits.

# VARIABLE INDUCTANCE TRANSDUCER

$$R = \sum_i \frac{L_i}{A_i} \frac{1}{\mu_i}$$

$L_i$  = length of the  $i_{th}$  tract

$A_i$  = section amplitude in the  $i_{th}$  tract

$\mu_i$  = permeability of the  $i_{th}$  tract (1 if air, 1000÷10000 in case of ferromagnetic materials)

In the circuit drawn in the figure the reluctance mainly depends on the air tracts. Therefore:

$$R = \frac{2x}{A\mu_{aria}}$$

Since the inductance  $L$  is equal to:

$$L = \frac{n\Phi_B}{I} = \frac{n^2 I}{R I} = \frac{n^2 A \mu_0}{2x} \quad \Rightarrow \quad Y (\text{ admittance } ) = \frac{2x}{\omega n^2 A \mu_0}$$

**Thus by providing the circuit with a suitable voltage and by measuring the current  $I=VY$  obtained, the achieved measurement is  $\propto$  to the  $x$  displacement as expected (linearity)**



# VARIABLE INDUCTANCE TRANSDUCER

- Typical usage: two transducers
- When the distance  $x$  augments the second transducer compensates the 'fraying' of the force lines that would modify the value of the section A
- The coil number can be used to tune the transducer sensibility
- A bridge circuit is used to carry out the differential measurement requested by two transducers
- The measurement can be done even at relatively low frequencies but normally is done at 100 Hz – 1 KHz
- Possible application to measure very hot objects without any dangerous contact

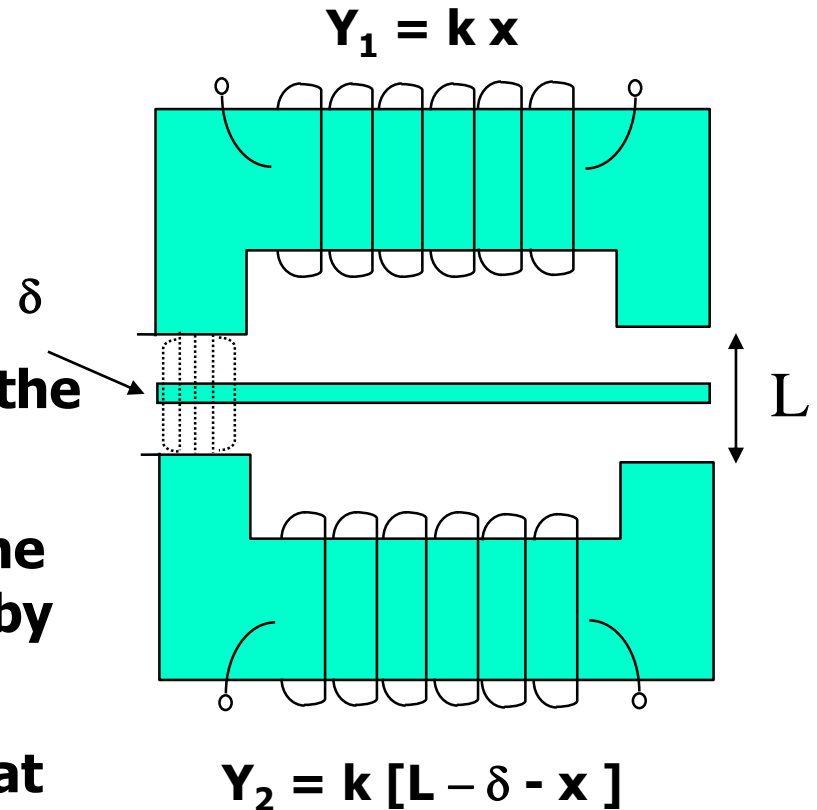

# ANGULAR POSITION TRANSDUCERS

They are used when it is not easy to employ a linear position transducer (i. e. the position of a moving object on a rail)

Often used to convert a linear (long) displacement moving along a gear rack using *screws*. The position will correspond to many turns (full circles)

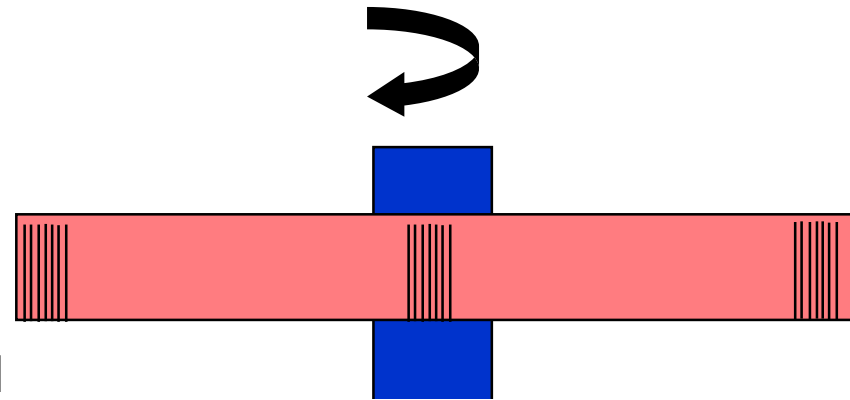

## Circular potentiometer

$$V = \frac{\vartheta}{2\pi} E \text{ with } \vartheta < 2\pi$$

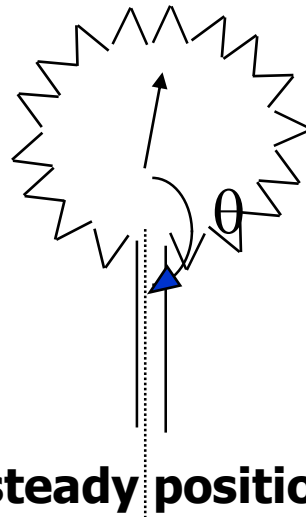

- Ok if oscillations around steady positions
- «no measure» (death) zone (around 0°)
- possible ambiguities

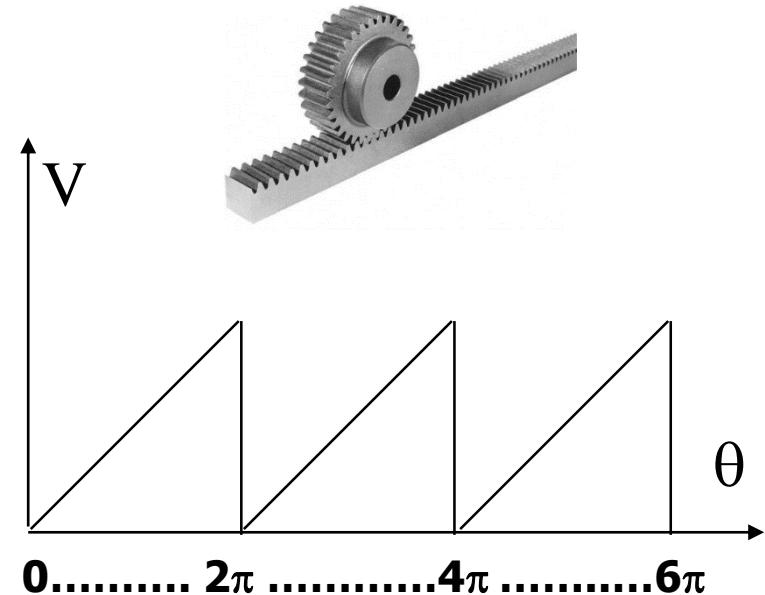

# ENCODERS (optical measurement systems)

A disk-plate equipped with windows transparent to the light interchanged with others opaque

The light is provided by a LED and received (when possible) by a photomultiplier (phototransistor)

Every window provides a binary information

The shaft is connected to the object of which we want to calculate the angular position or velocity

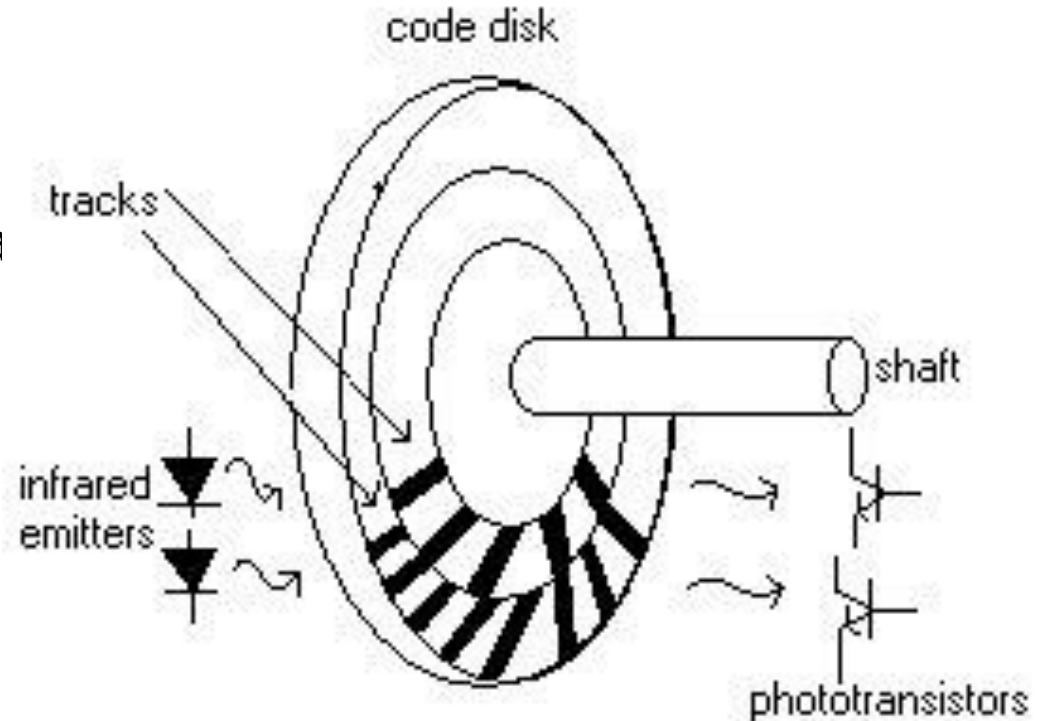

# ABSOLUTE ENCODER

Pure binary code

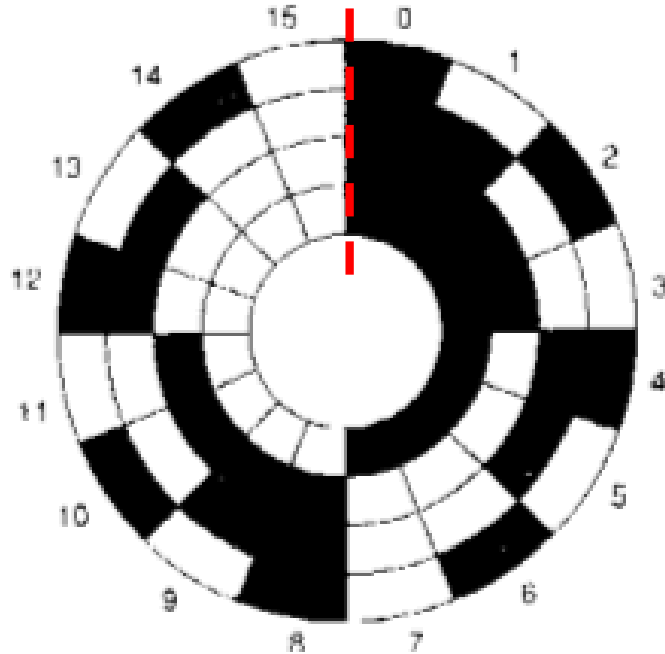

Gray code

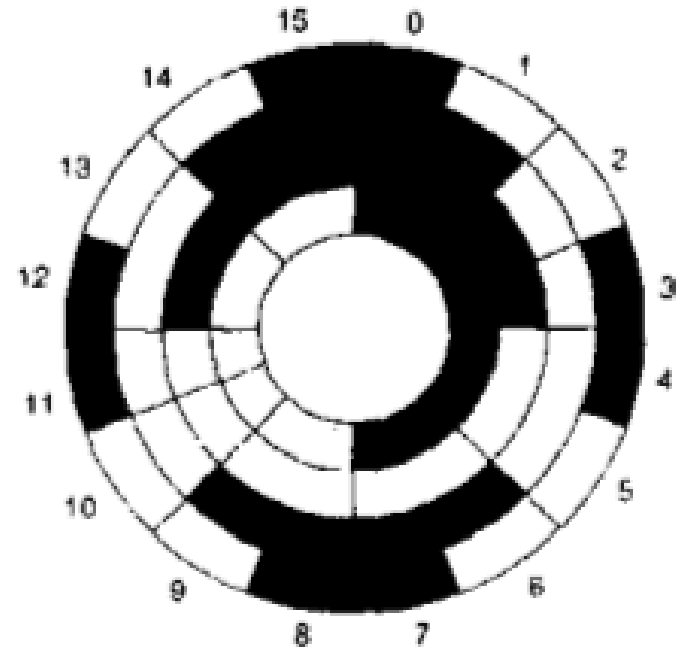

**Angular codification with 16 different values per every angle  $\Rightarrow$  4 bits: 4 concentric crowns are used with opaque/transparent windows on a 1 by 1, or 2 by 2, 4 by 4 and 8 by 8 basis. Minimum step is  $22.5^\circ$**

**4 LED + phototransistor couples are necessary suitably aligned**

**Gray codification to avoid that 2 or more bits change simultaneously (aligning and lighting errors)**

# ABSOLUTE ENCODERS

---

- Cheap and with good precision for typical angular rotations
- If more  $N^\circ$  of turns?
- What is the movement direction?

## POSSIBLE SOLUTION

- If rotating in only one sense: external sectors are counted through a hw counter (bidirectional: it can increment or decrement its value): when the count reach  $2^N$  a turn has been performed
- But if the direction can be changed no other possibility than using an incremental encoder

# INCREMENTAL ENCODER

Two concentric crowns 1/4 of the period phase shifted

Two LED/phototransistors couples (1 light, 0 darkness)

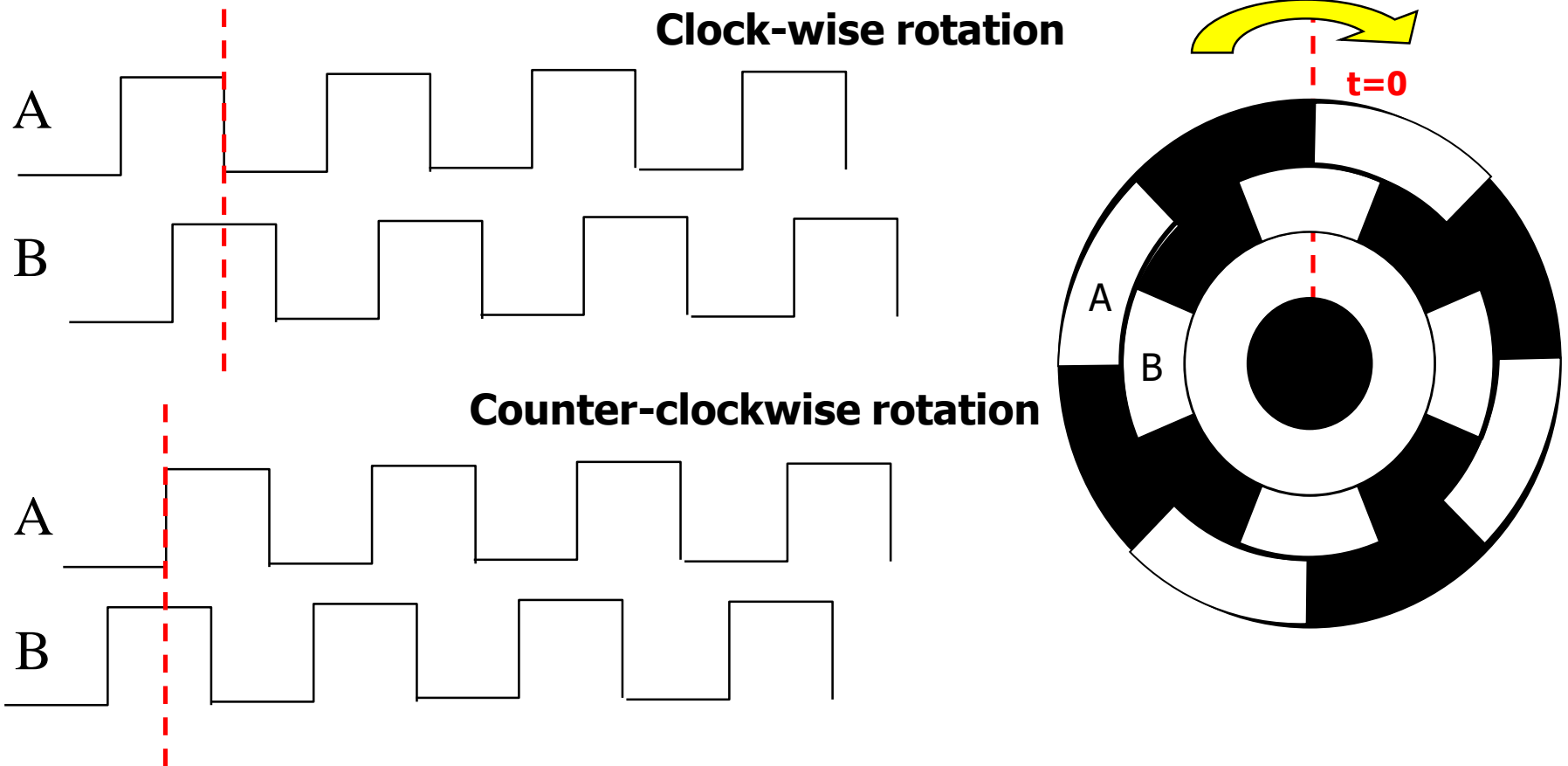

# INCREMENTAL ENCODER

- Minimum angle to be measured = 1/2 window
- Detecting direction inversion

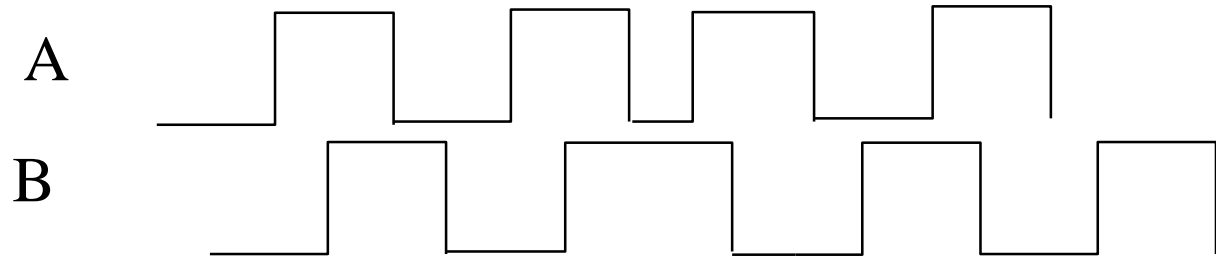

- Counting algorithm



$S_1$	$S_2$	$S_3$
P	0	+1
P	1	-1
N	0	-1
N	1	+1
0	P	-1
1	P	+1
0	N	+1
1	N	-1

- Output = pulses
- Pulses must be read by a microprocessor or if they are too fast through a counter

# VELOCITY TRANSDUCERS

*Can we obtain the velocity as the derivative of a position transducer (and vice-versa)?*

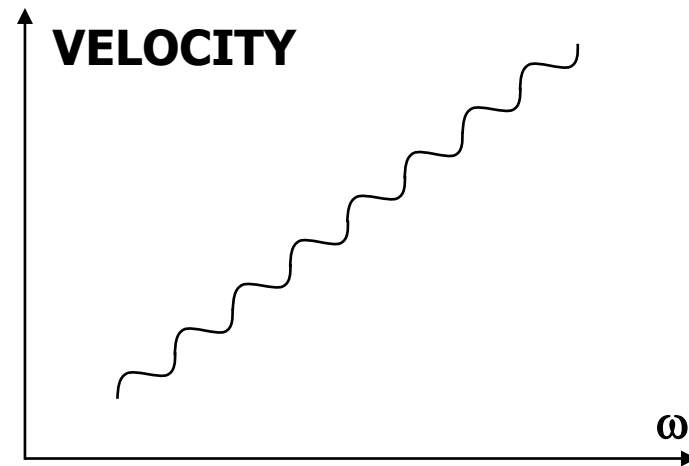
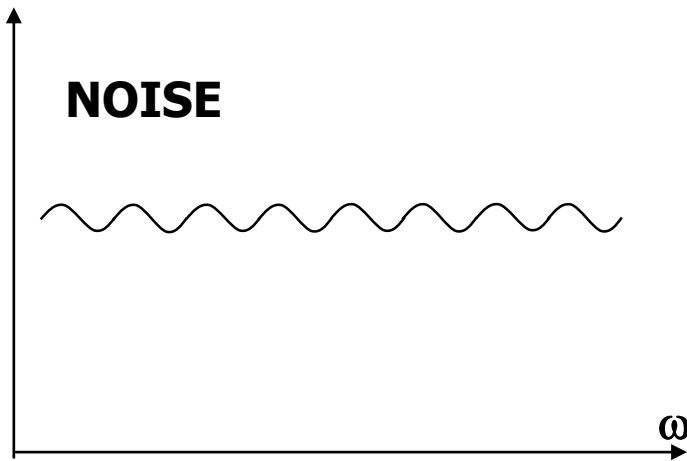

**The noise is typically present at high frequencies that play an important role when the magnitude we are interested to is obtained by derivation.**

**Unfortunately a low-pass filter eventually cuts the velocity components at high frequencies. Moreover, eventual non linearities are intensified (i. e. potentiometer)**

**Similar considerations can be done when working at low frequencies in case we would obtain a position by integrating the velocity obtained by a velocity transducer (1/s).**



# LINEAR VELOCITY TRANSDUCER

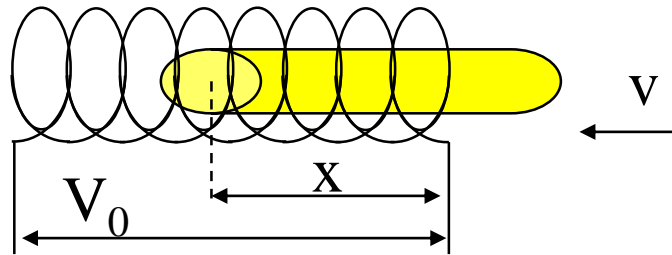

## Electromagnetic transducer

**A nucleus of ferromagnetic material moving within a solenoid (permanent magnet).**

**Measured voltage  $\propto$  flux variation therefore to the velocity.**

$\Phi_c = N_c \Phi_B$        $\Phi_B$  permanent magnet flux,  $N_c$  coils enchainned with the magnet  
 $N_c = nX$            $N$  is the coil number vs length unit (density)

$$V_0 = - \frac{d(N_c \Phi_B)}{dt} = - n \Phi_B \frac{dX}{dt} = - n \Phi_B V$$

• **Approximated measurements**

• **Suitable to small velocities: if big it is better to transform the linear displacement into an angular one measuring the angular velocity**

# VELOCITY calculation with the ENCODER – sw approach

---

- 2 pulse train: A and B
- Commutations are detected
- Displacement direction detection: forward (+) or backward (-)
- Counters must be used
- Algorithm (Hp. clockwise > 0)

*if B commuted*

*if B=A count++*

*else count--*

*else if A commuted*

*if A=B count --*

*else count ++*

*end if*

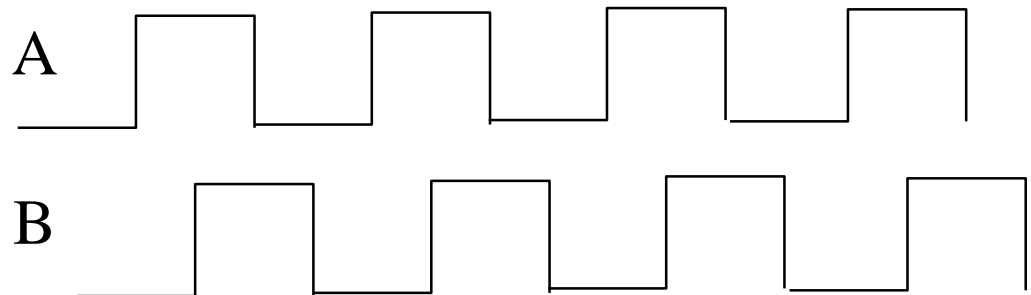

# VELOCITY CALCULATION

---

Encoder pulses are counted into a interval of time

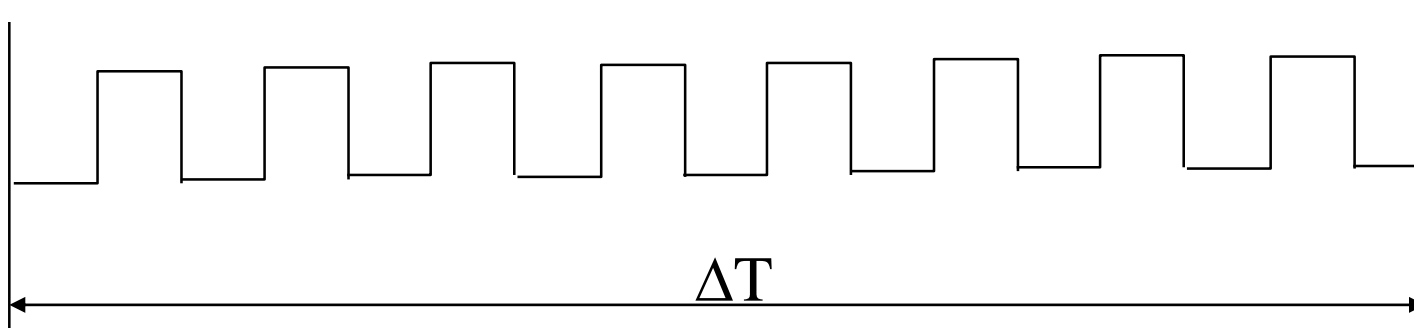

The period between two pulses is evaluated  $T_{ck}$



**It's an average value!**

# ANGULAR VELOCITY TRANSDUCERS

## TACHOMETRIC DYNAMO (ring of Pacinotti)

transforms a velocity into a proportional voltage

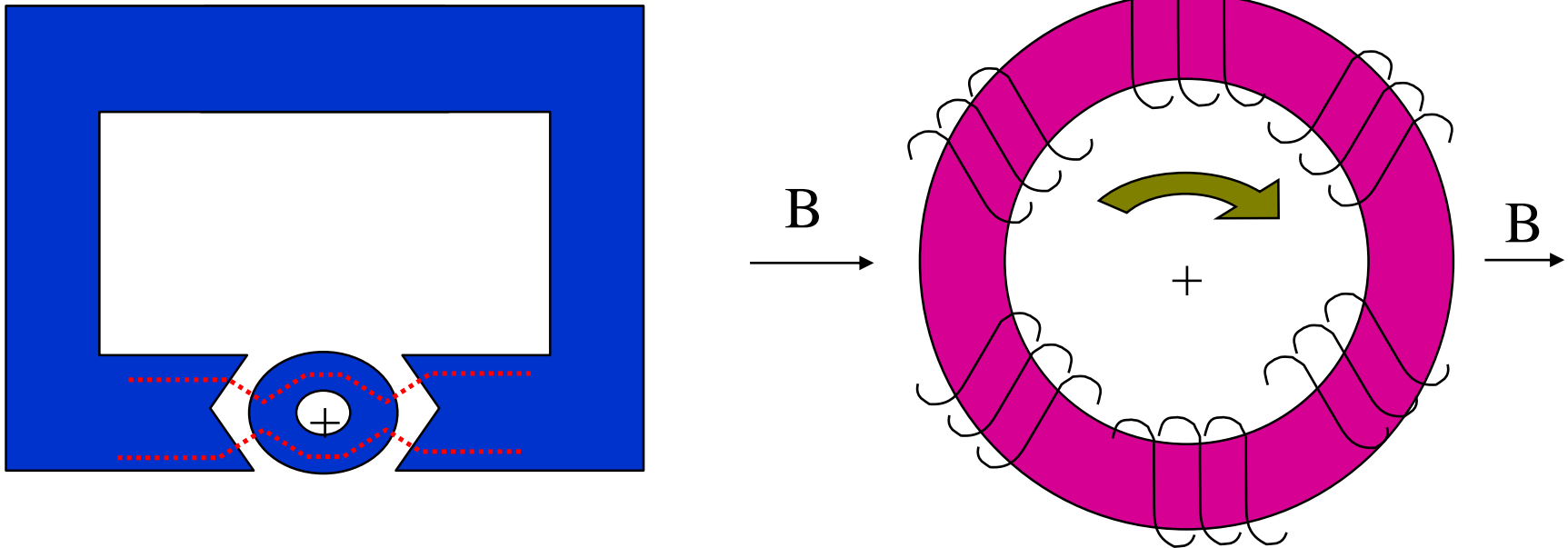

The force lines are kept inside the magnet or in the rotating ring that features very high magnetic permeability.

The ring is inserted into a field  $B$  that (due to the rotation) generates an electric field  $E$  and therefore an electromotive force (f.e.m) in each rotating coil.

# TACHOMETRIC DYNAMO

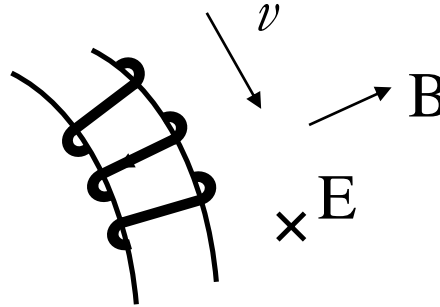
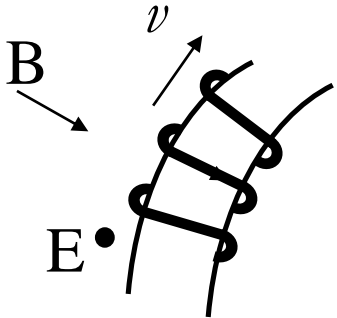

$$E = B \times v$$

$$V = \int E \cdot dl$$

**Within the coils the electromotive forces generated by the movement of the ring in the field are equal and opposite  $\Rightarrow$  no contribute  $\neq 0$**

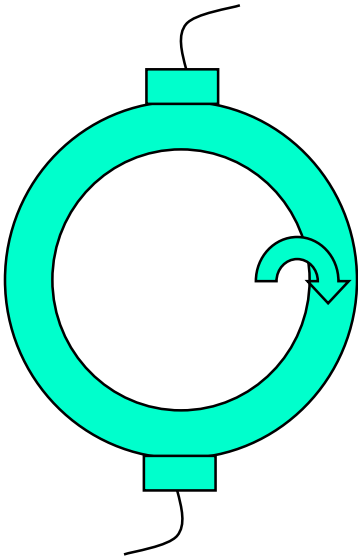

**However if we insert two contact clamps that take current on top and bottom of the ring (where the  $dl$  element is parallel to  $E$ ) a voltage  $\neq 0$  can be measured.**

**This voltage is proportional to the velocity of the ring**

# TACHOMETRIC DYNAMO

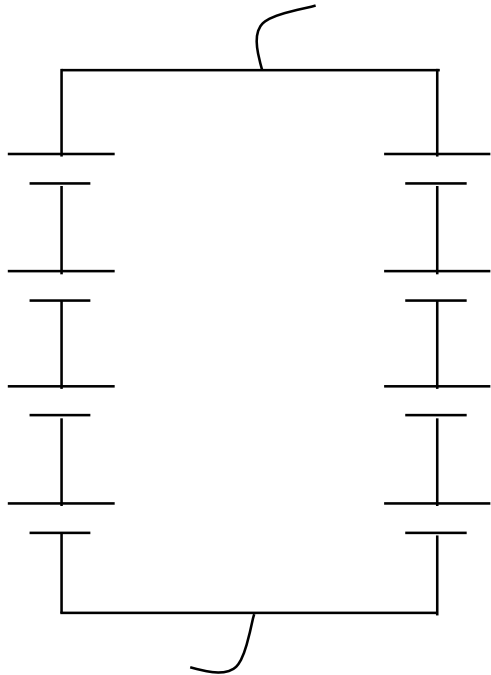

•The ring with all the coils can be modelled like as a voltage generator series in parallel with respect to the contact clamps (like small batteries).

•If  $n$ =total number of coils the voltage  $V$  measured at the extremities of the two wires is equal  $V_m * n/2$ .

• $V_m$  = average voltage induced in every coil.

$$V_m = B_m L v \text{ with } v \text{ velocity of the coils}$$

• $B_m$  average field  $\perp$  to the surface of the ring and to  $v$ .

• $L$  ring thickness and length of the coil irradiated by the field.

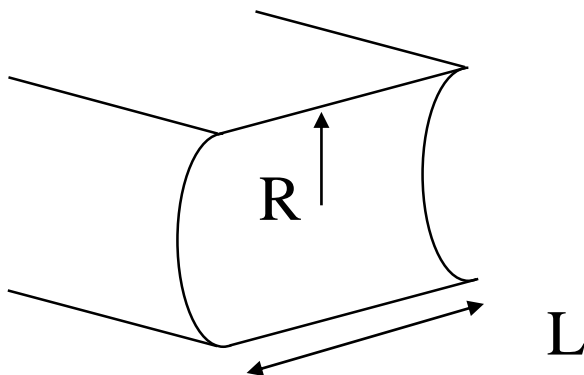

$$\Phi_B = \int B \, dS = B_m S = \pi R L B_m \quad \text{da cui}$$

$$V = \frac{n}{2} B_m L v = \frac{n}{2} \frac{\Phi_B}{\pi R} v = \frac{n}{2} \frac{\Phi_B}{\pi R} \omega R = n \Phi_B f$$

# TACHOMETRIC DYNAMO

**High voltages immediately usable (10V/1000 rpm)**

**Low output impedance**

**'ripple' effect due to the construction methods (1-2%)**

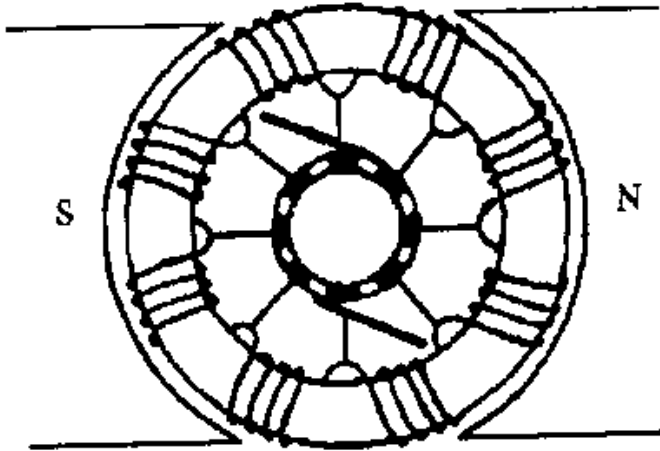

**Mobile contacts (brushes and plates)**

**Curt variation when passing from a plate to the successive one**

**f.e.m induced sinusoidal if uniform B field**

**No filtering since it depends on the rotation velocity**

**Use of generators without clamps to prevent from the noise due to sliding contacts**

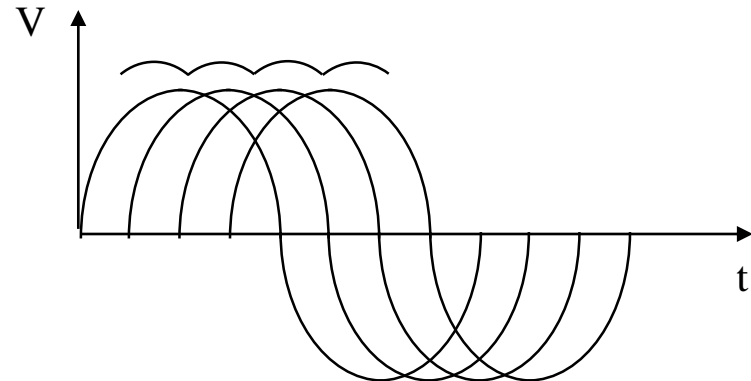

# TACHOMETRIC ALTERNATOR

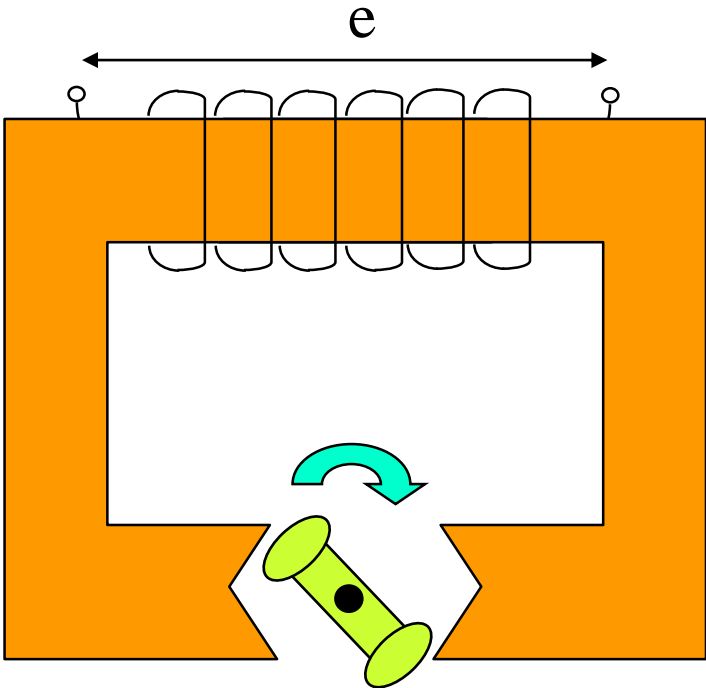

- **Permanent magnet that rotates within two expansions of a ferromagnetic toroidal ring with fixed wrapping.**
- **The flux of B is variable due to the rotor movement (alternate flux).**
- $\phi_B = \phi_0 \cos \omega t \Rightarrow$  and  $e = -n \frac{d\phi_B}{dt} = n\omega \phi_0 \sin \omega t$
- **Twice depending on  $\omega$  (this is a problem)**
- **The variability of a magnitude makes difficult to measure the other one.**
- **Generally speaking the information is considered associated to the frequency of the emitted signal.**



# INDUCTION-BASED GENERATOR

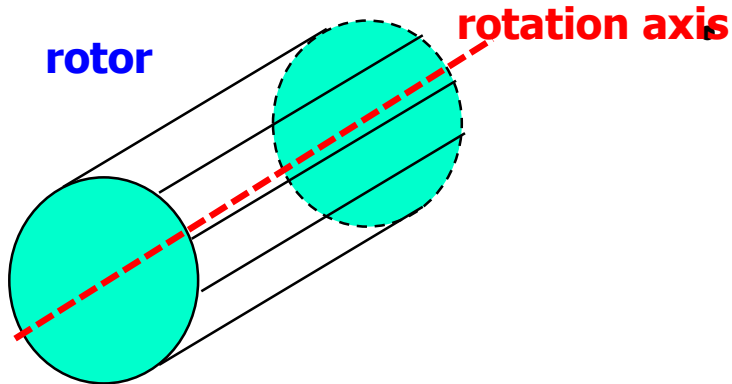

A rotating machine with two solenoidal stators and 1 rotor acting like as a *squirrel cage* with rectilinear conductors and 2 connecting rings.

- Due to the rotation the first stator couples with the cage and this in turn with the second one generating induced voltages.
- If the rotor is steady no voltage is generated.
- The first stator is AC power supplied. A magnetic field  $B$  arises that creates induced currents in the rotor conductors (due to the its movement).
- On turn this induces a voltage in the coils of the second stator.

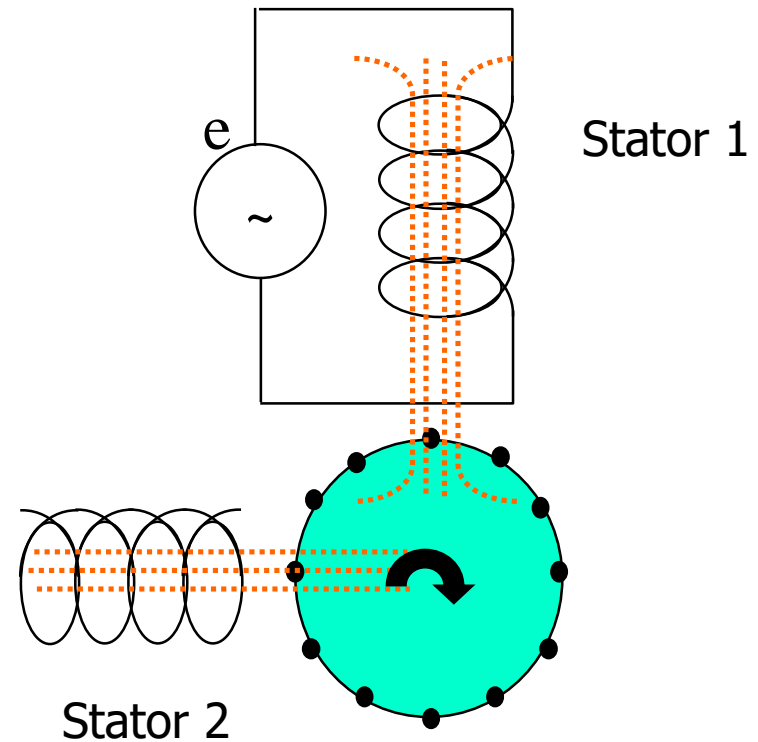

# INDUCTION-BASED GENERATOR

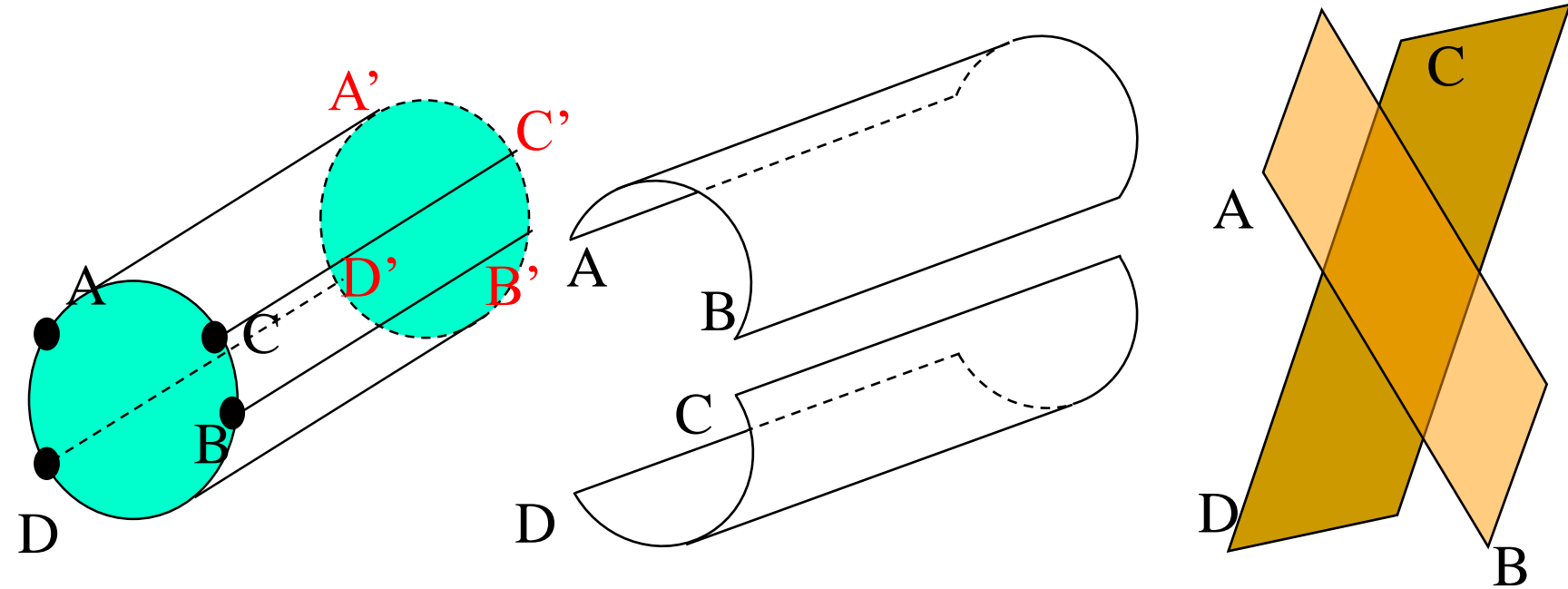

**A-B-A'-B' and C-D-C'-D' are symmetrical circular arcs connected by conductive rod couples that identify 2 semi-circular surfaces (spherical caps). If we «stretch» them we obtain two parallelogram-shaped coils that mutually cross. This represents an approximation since we will not consider the curvature effect on the magnetic irradiation.**

# INDUCTION-BASED GENERATOR front section

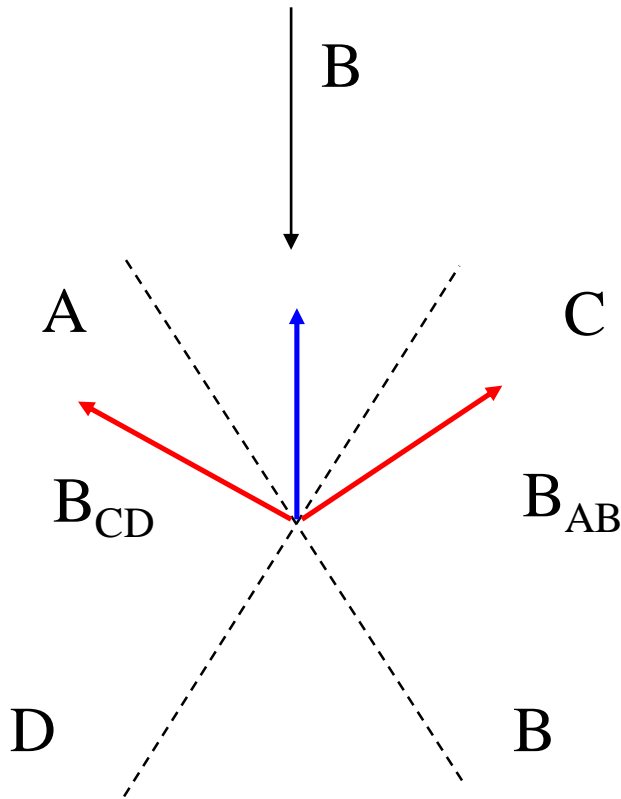

- $B$  is vertical.
- If the cage does not move, the flux of  $B$  induces a current in the coil  $AB$  that develops on turn an induced field  $B_{AB}$  that tends to be opposed to generating cause (Faraday Neumann + Lenz law).
- The same consideration can be done about coil  $CD$ .
- $AB$  and  $CD$  are symmetric therefore  $B_{AB}$  e  $B_{CD}$  (vertical to the coil surface) provide a resulting field facing upwards that does not couple with the II statoric solenoid.
- No current in the secondary circuit in this case.
- Now let's suppose the cage rotating clockwise ...

# INDUCTION-BASED GENERATOR front section

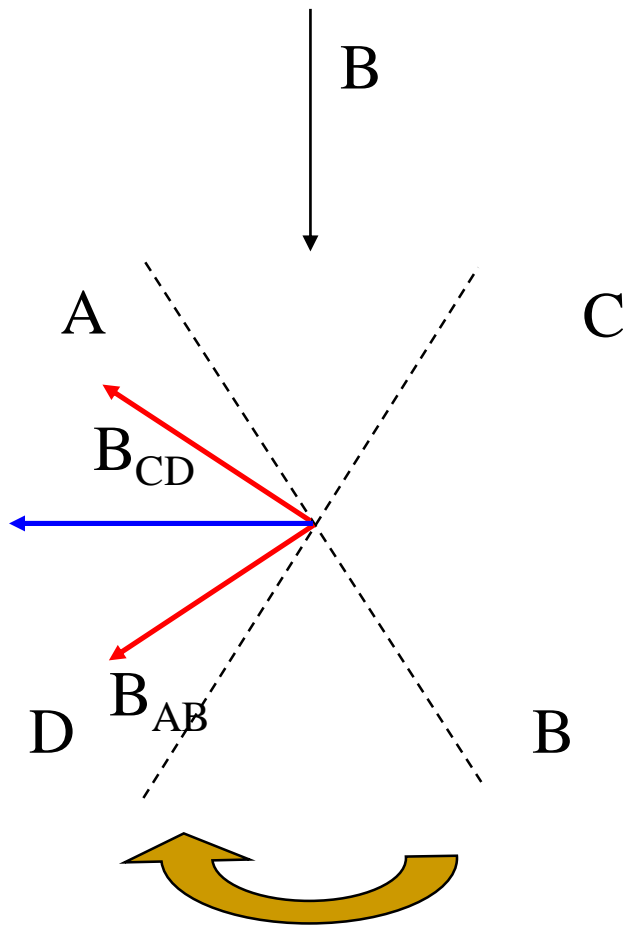

- $B$  is vertical.
- If the cage rotates, the flux of  $B$  crossing the  $AB$  coil diminishes (the effective coil surface is smaller).
- This induces a current in the coil  $AB$  and an induced field  $B_{AB}$  that opposes to the generating cause therefore this time is downward oriented (i. e. strengthen the field whose flux diminishes).
- About the  $CD$  coil the consideration is similar as before.
- This time  $B_{AB}$  and  $B_{CD}$  (vertical to the coil surface) provide a horizontal resulting field that couples with the secondary solenoidal stator.
- An induced current is born in the secondary and a f.e.m with frequency equal to the power supply  $e(t)$ , direction depending on the rotation type and amplitude proportional to the velocity.

Conditioning network: synchronous rectifier

# CAPACITIVE CHARGE/DISCHARGE TRANSDUCER

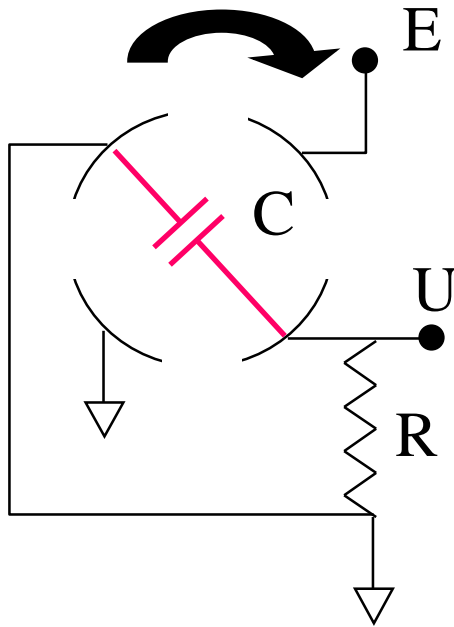

- The produced output features constant amplitude and variable frequency (the velocity to be measured)
- When the ring rotates the capacitor charges and discharges alternatively
- The maximum charge value is  $E$ , the discharge is made through the  $R$  resistor
- Every round the capacitor is charged/discharged two times

• Frequency depends on the rotation velocity (max.  $4/T$  to allow  $C$  to discharge)

• The output variable is an angular position (if related to a time  $\Rightarrow$  velocity)

• A reversible frequency-meter made up by a pulse counter can be used. Reversible to estimate the rotation sense

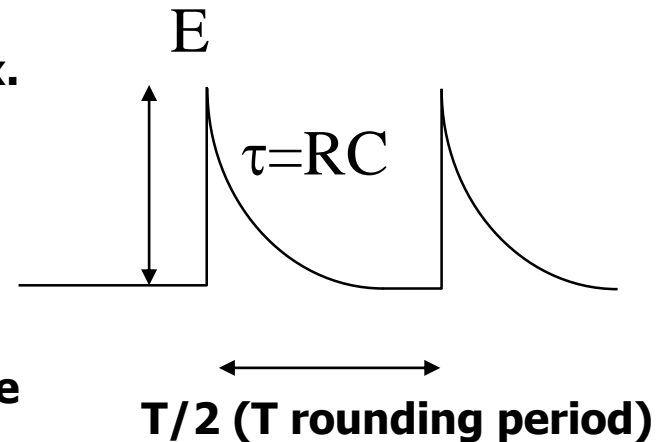

# CAPACITIVE CHARGE/DISCHARGE TRANSDUCER

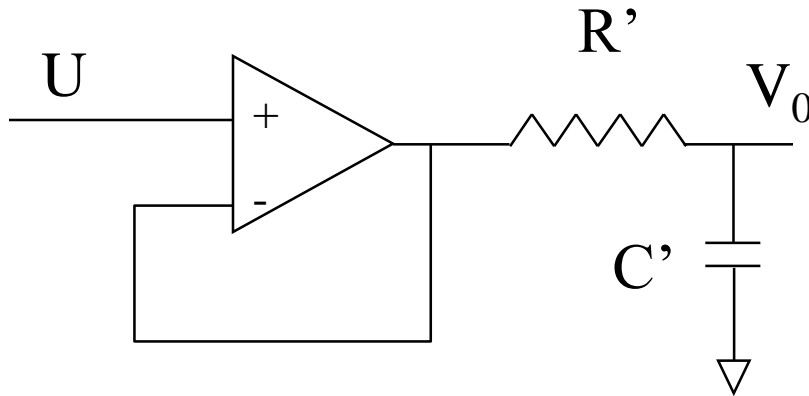

- As an alternative a low pass filter can be used (approximated integrator) with  $R'C' \gg T/2$
- The output will be  $\cong$  average of the voltage provided by the transducer
- $V_0 = 2ERC/T = 2fERC$
- $f$ =rotation frequency

•If the rotation is inverted the sign is inverted

•The integrator is less precise than the frequency-meter and limits the velocity measurements (since the discharge must happen in a time = to  $5RC$  that corresponds to  $T/4 \Rightarrow$  be careful to the size of  $R$  and  $C$ ).

# ACCELERATION TRANSDUCERS

---

- **Same problems as before if acceleration is obtained as derivative function of the velocity**
- **The acceleration is independent on the considered reference system**
- **No need of circuit that refer the measurement to a fixed reference point (origin)**
- **The acceleration will be measured on a suitable point and then it will be valid for every system into which the object is moving**
- **Sometimes single and double integration to achieve position and velocity (critical at low frequencies and need of expensive hw to have enough accuracy)**

# MOVING MASS ACCELEROMETER

- The mass moves in the opposite direction to the acceleration one
- Damping piston to stop the oscillation
- $X$  = displacement relative to the object that contains the accelerometer
- $x$  = displacement of the object with respect to a fixed reference point

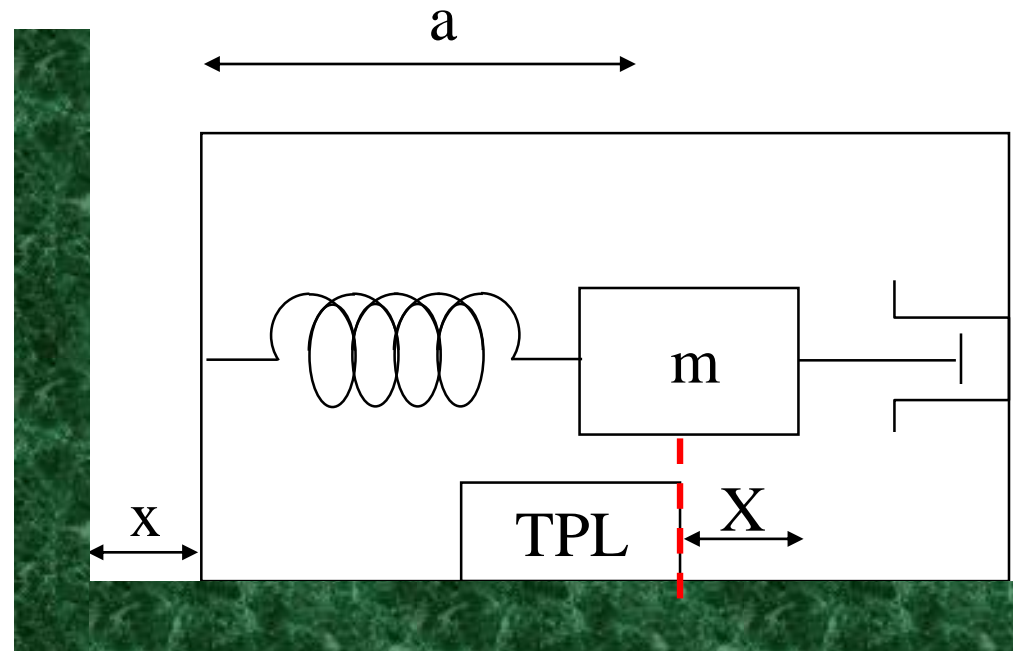

$$F = ma_m = m(\ddot{x} + \ddot{X})$$

$\ddot{x}$  = object acceleration

$$F = -kX - \gamma\dot{X}$$

$\gamma$  = viscous friction coefficient

$$ma = -(m\ddot{X} + \gamma\dot{X} + kX) \Rightarrow ma = -(ms^2 + \gamma s + k)X$$

$$\frac{X}{a} = -\frac{m}{k} \frac{1}{1 + \frac{\gamma}{k}s + \frac{m}{k}s^2}$$



# MOVING MASS ACCELEROMETER

- **If  $s=0$  (regimen)** 
$$X = -\frac{m}{k} a$$
 with  $m/k$  sensibility of the transducer
- **If variable frequencies**  
damping oscillator with double pole in  
obtained by evaluating the solutions of  
the denominator with  $\gamma = 0$   
$$\omega_T = \sqrt{\frac{k}{m}}$$
- **Oscillation frequency is inversely proportional to the sensibility**

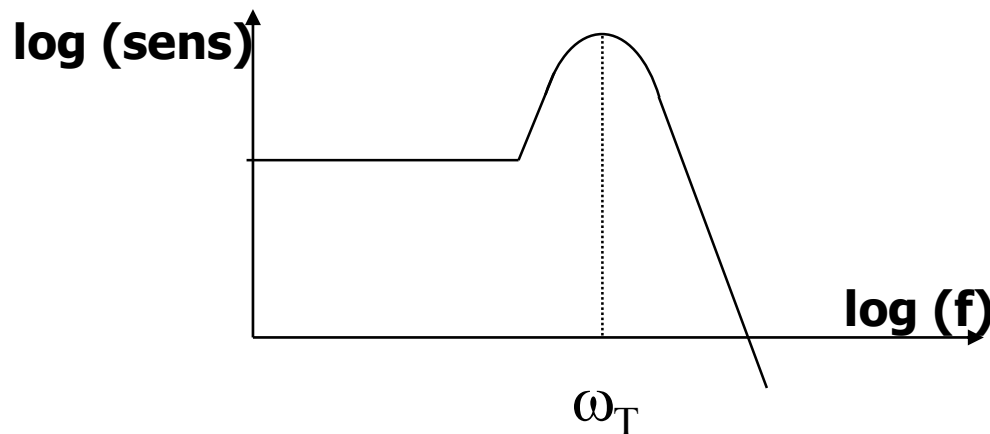

To work with constant sensibility working frequencies must be confined before  $\omega_T$

Alternatively we need servo-accelerometers or piezoelectric materials that allow to work at very high frequencies

# MOVING MASS ACCELEROMETER

## Complex conjugate poles diagram

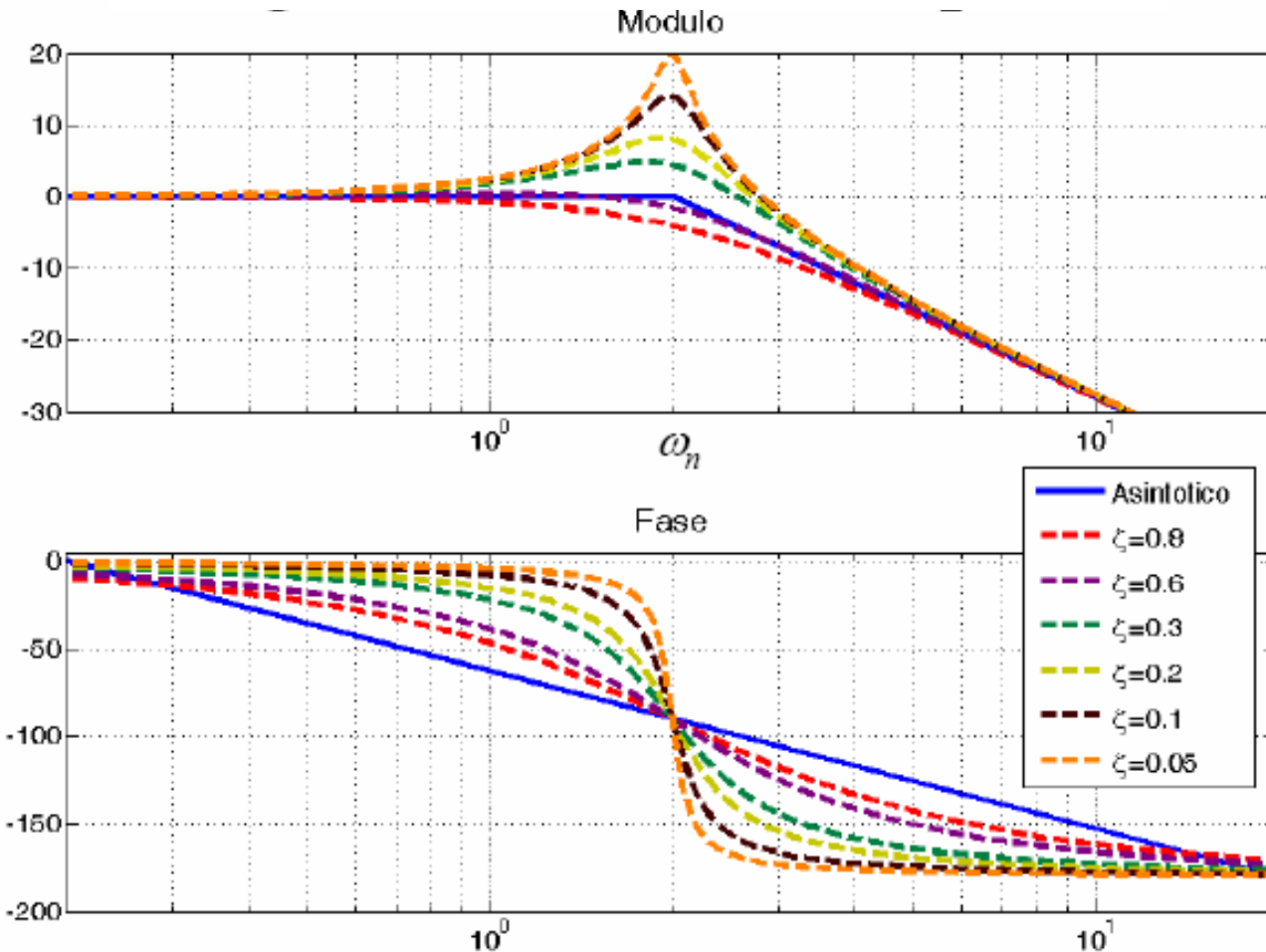

$$\frac{1}{\left(1 + j \frac{2\zeta\omega}{\omega_n} - \frac{\omega^2}{\omega_n^2}\right)}$$

# SERVO-ACCELEROMETER

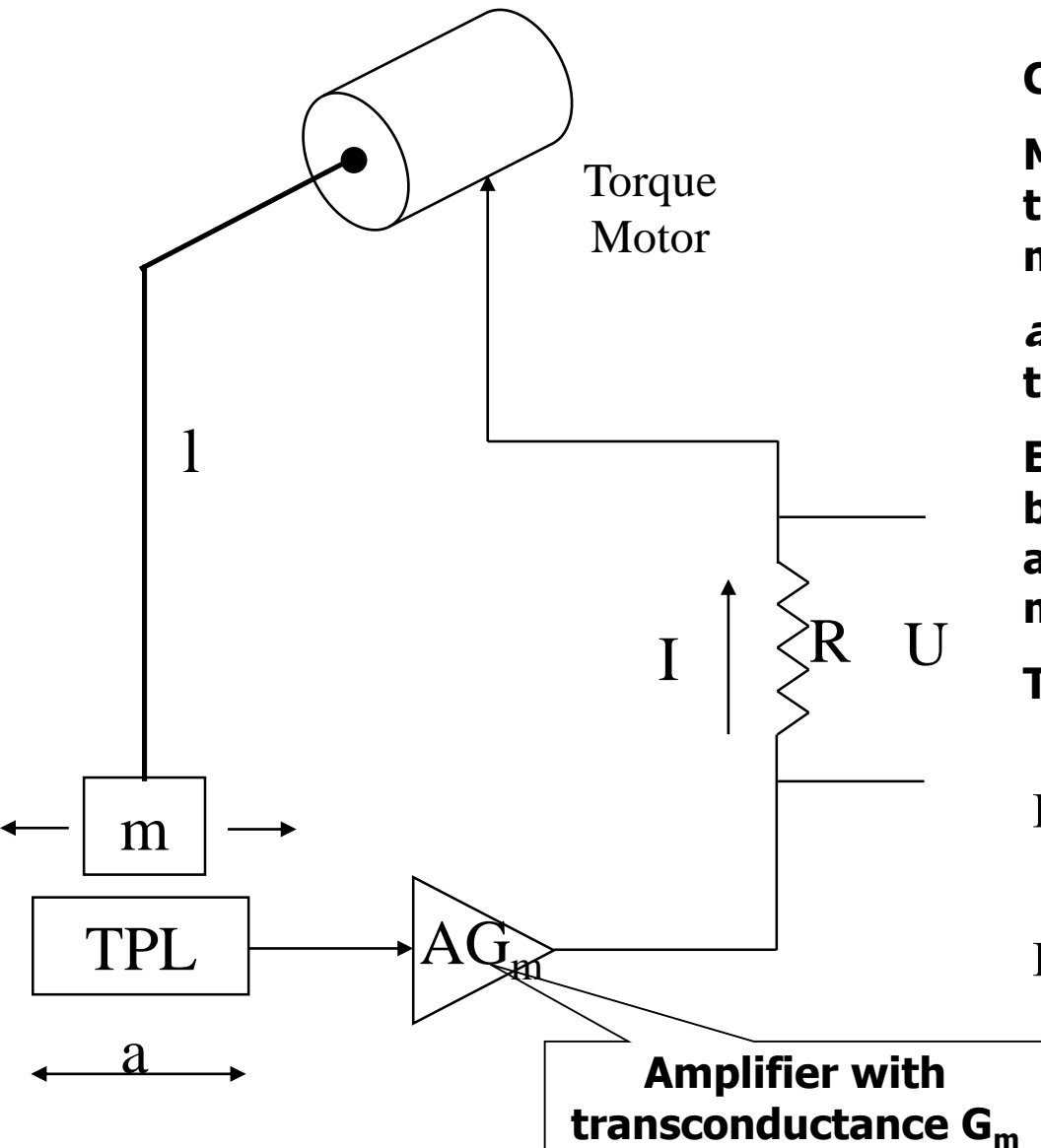

**Constant sensibility at all frequencies**

**Motor connected to a shaft that makes the small mass  $m$  to perform small movements**

**$a$  makes the mass  $m$  to oscillate around the steady position**

**Every small movement is transformed by TPL and AG<sub>m</sub> into a current  $I$  that activates the motor so as it takes the mass back in the original position**

**The motor develops a torque**

$$\Gamma = k_m I \quad k_m \text{ motor characteristic}$$

$$\Gamma = ma l \quad \text{Torque applied to the mass } m$$

# SERVOACCELEROMETER

---

**When the system is stable the motor torque = oscillating mass torque**

$$U = RI = R \frac{\Gamma_m}{k_m} = \frac{mRl}{k_m} a \quad \text{Constant sensibility}$$

**We introduced in the system a very sophisticated «spring» (damping factor) made up by the amplifier, the transconductance, the motor whose 'elasticity constant' is ( $S_t$  transducer sensibility):**

$$k_{eq} = \frac{F}{\Delta x} = \frac{\Delta x S_t A Gm \frac{k_m}{1}}{\Delta x} = S_t A Gm \frac{k_m}{1}$$

# OBSERVATIONS

---

- **Several parameters allow to change the sensibility. The most suitable one is the resistance  $R$**
- **The elasticity constant depends on electrical parameters and not only mechanical ones  $\Rightarrow$  the spring can be improved without changing the sensibility.**
- **No damping oscillation; components can be more easily controlled**
- **In normal conditions the parts of the transducer are in fixed positions: better linearity**
- **TPL is linear if small  $m$  movements, not linear if large oscillations**
- **Not suitable at high frequencies (100 KHz). In this case a piezoelectric ceramic accelerometer is advisable**

# PIEZOELECTRIC ACCELEROMETER

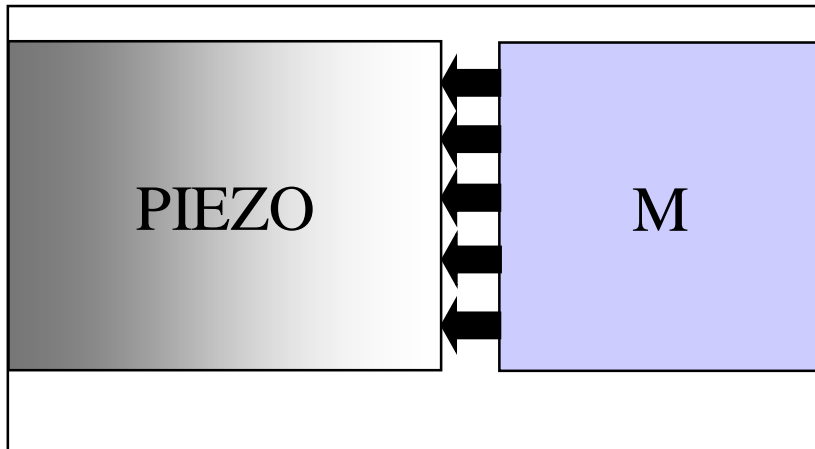
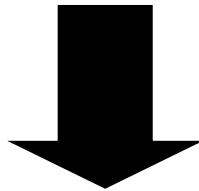
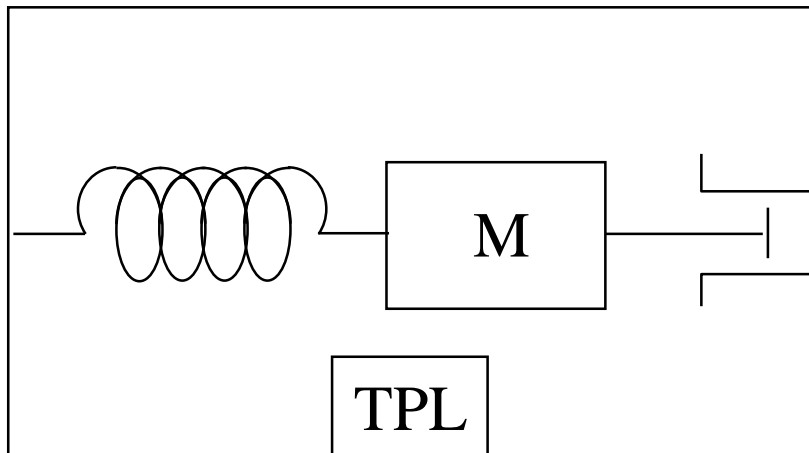

The piezoelectric ceramic when compressed generates a voltage that can be measured

High sensibility: a very stiff transducer with high  $K_{eq}$  that allows to work at very high frequencies

$$ma = -m\ddot{X} - k_P X$$

$$\frac{X}{a} = -\frac{m}{k} \frac{1}{1 + \frac{m}{k_P} s^2} \quad \omega_{RIS} = \sqrt{\frac{k_P}{m}}$$

# PIEZOELECTRIC EFFECT

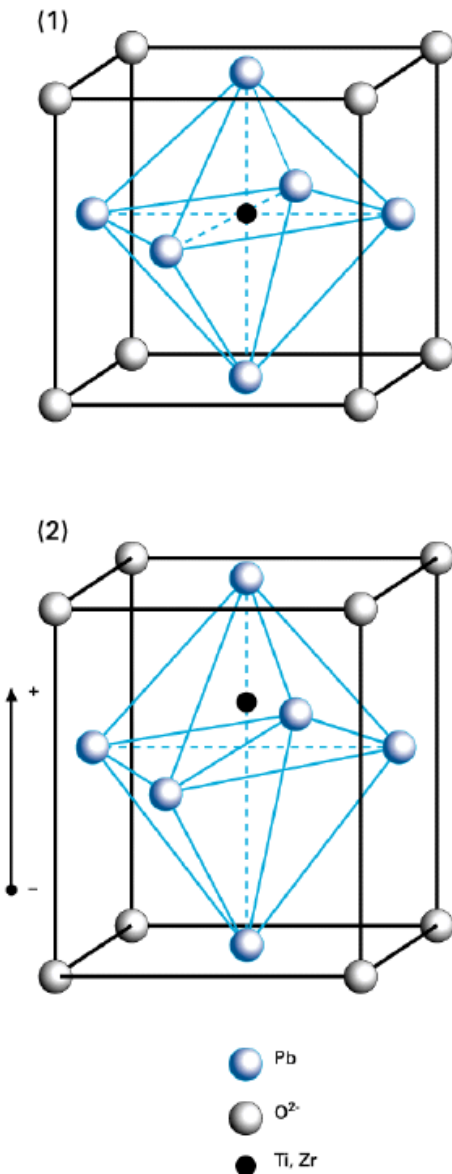

**Piezoelectric effect: a material that if compressed produces a measurable voltage or conversely if subject to a electric field can distort (reversibility).**

**Typical materials: titanate of Ba ( $\text{BaTiO}_3$ ) o PZLT (Piezo Lead Zirconate Titanate).**

**A piezoelectric crystal corresponds to a lattice with oxygen atoms in the vertices, metallic atoms in the face centers and in the a heavy atom in the center located in the minimum energy seat (fig. 1).**

**This structure is metastable (easy to modify).**

**If an electric external field is present, the Titanium o Zirconium atom moves from its steady position and causes an imbalance that transforms the crystal in an electric dipole (fig. 2).**

**The phenomenon can be detected up to a characteristic (Curie) temperature. Above this threshold the thermal agitation makes it to disappear.**

# PIEZOELECTRIC EFFECT

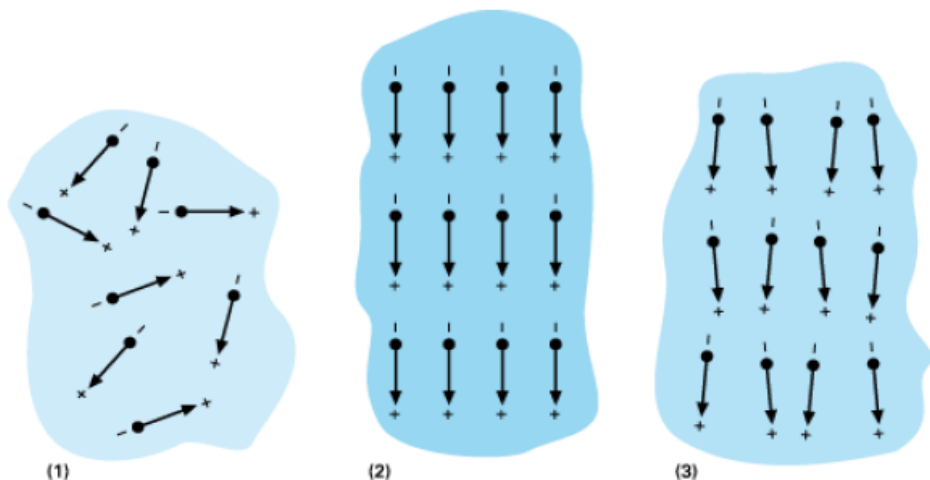

The previous property is used to obtain anisotropic PZT materials.

In nature (fig. 1) PZT materials do not have preferred orientations so they are poor to deform or to provide an electric signal if warped.

Artificially, conversely, the PZT are warmed up beyond the Curie temperature and undergo to an intense electric field during the chilling that makes the dipoles to uniformly orient so as to have a steady polarization (fig. 2).

This stable polarization causes an overall deformation of the material determining a slight stretching. If now an external electric field is applied in the same direction of the polarization (but less coherently) the material will compress since the direction of the field is not completely parallel to the polarization (fig. 3). This behavior can be considered present up to a limit value of the field said *coercive field*.

The phenomenon is dual: if compressed or stretched, electrical charges can arise on the surface material dual with respect to the internal field.



# PIEZOELECTRIC ACCELEROMETER

The electrical behavior of a material can be in general described by:

$$\vec{D} = \epsilon \vec{E}$$

- $\epsilon$  dielectric constant of the medium,  $D$  density of the charge distribution on the surface of a conductor material merged into an electric field  $E$

$$\vec{S} = s \vec{T}$$

- $S$  deformations tensor (3x3 matrix),  $T$  forces tensor,  $s$  elasticity constant (Hook)

If a squashing or traction direction is fixed the three deformation ( $x, y, z$ ) components of a material can be measured.

If the traction is applied along three axes, every components group along the three directions identifies the  $S$  tensor.

In our case, for sake of simplicity, we will consider only those linear deformations parallel to the electric field applied just since we are considering anisotropic materials.

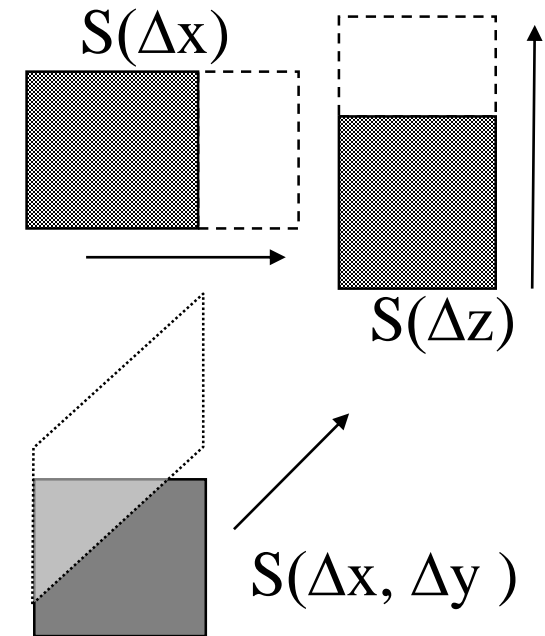

# PIEZOELECTRIC ACCELEROMETER

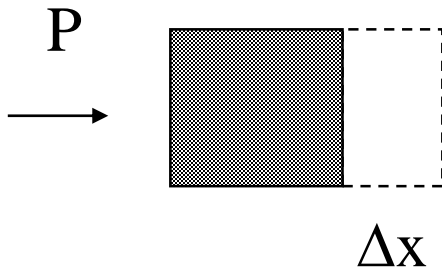

$S = sT$  where  $T = P = \text{force on the surface} = F/A$   
 $S = \text{stretching } \Delta X/L, s \text{ elasticity constant}$

For PZT materials previous equations are different: a new  $h$  coefficient introduces the effect in terms of charges distribution due to the mechanical action.

Let's suppose now that a small mass  $M$  that is moving with  $a$  acceleration compresses the PZT (or viceversa) and let's evaluate the transducer sensibility.

Due to the acceleration a compression force arises  $F = Ma$  by the mass  $M$  towards the PZT material.

The force tensor  $T$  is,  $T = Ma/A$  ( $A$  contact surface).

Suitable metal plates (plaques) to achieve the charges so as to measure a corresponding voltage. The cylindric piezoelectric transducer is equivalent to a capacitor  $\Rightarrow$  cannot work in direct current.

$$\vec{D} = \epsilon \vec{E} + h \vec{T}$$

$$\vec{S} = s \vec{T} + h' \vec{E}$$

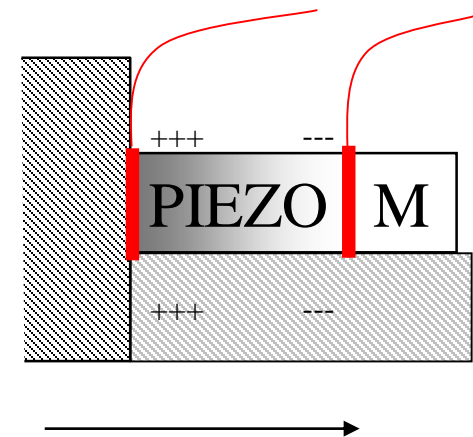

# PIEZOELECTRIC ACCELEROMETER

How to measure the charge distribution that originates from the traction on the PZT material?

2 possibilities: charge (current) amplifier or voltage amplifier.

**1. Charge (current) amplifier**,  $Z_{in}=0 \Rightarrow E=0$ , in static conditions the external field due to the dipolar charges inside the PZT material is constantly cancelled by the low input impedance of the amplifier (the +/- inputs are at the ground). The sole charge measurable variation is that due to the mechanical effect.

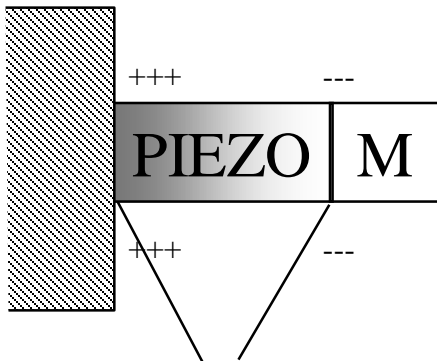

$$D = hT = h \frac{M}{A} a \quad \Rightarrow \quad Q = DA = hMa$$

The current measured by the amplifier should be integrated to obtain the charge  $Q$  and so (as we will see) the measure of the acceleration

Charge (current) amplifier

$$Q = \int I dt$$

# PIEZOELECTRIC ACCELEROMETER

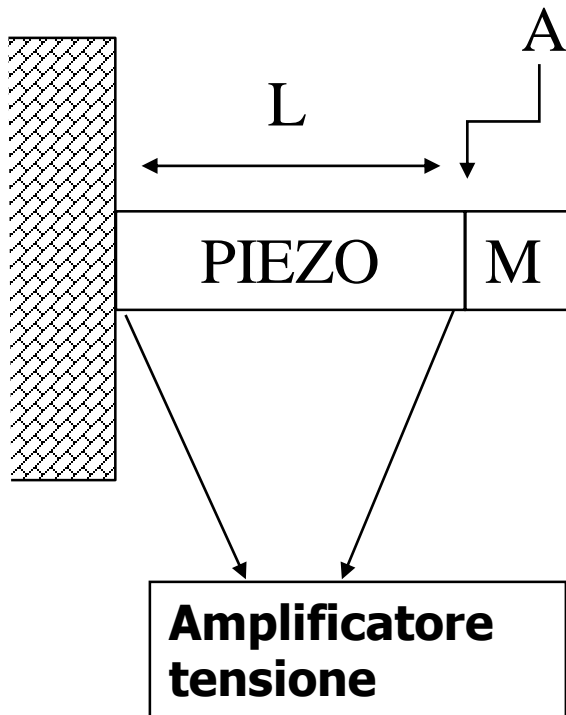

**2. Voltage amplifier,  $Z_{in} = \infty$ ,  $D = 0$  (Gauss).**

**The voltage amplifier features a input impedance that prevents charges from originating on the surface (metal plates) of the PZT transducer**

$$Q = DA = \int I dt = 0$$

$$E = -\frac{hT}{\varepsilon} = -h \frac{M}{\varepsilon A} a$$

$$V = -LE = h \frac{LM}{\varepsilon A} a = h \frac{M}{C} a$$

This kind of conditioning circuit “highlights” the capacitive nature of the transducer.

Other capacitive components due to the wiring cables must be considered as in parallel to  $C$  so as to modify (unfortunately) the transducer sensibility.

# PIEZOELECTRIC ACCELEROMETER: problems

## CHARGE (CURRENT) AMPLIFIER

- The C capacitor (for the measurement) is discharged (emptied) by the polarization currents
- The amplifier can saturate (use a switch)

$$Q = \left( -\frac{1}{R} \int E \, dt + \int I_{\text{parassite}} \, dt \right) \frac{1}{C}$$

## VOLTAGE AMPLIFIER

- Parasite capacitors disturb the output signal (they are in parallel to the C of the transducer)

## CHARACTERISTICS

- **OUTPUT RANGE:** 4mA-20mA;
- **BAND:** 20-1000 Hz;
- **SENSIBILITY:** 0-10 MM/SEC<sup>2</sup>
- **WEIGHT RANGE:** fino a 50 g

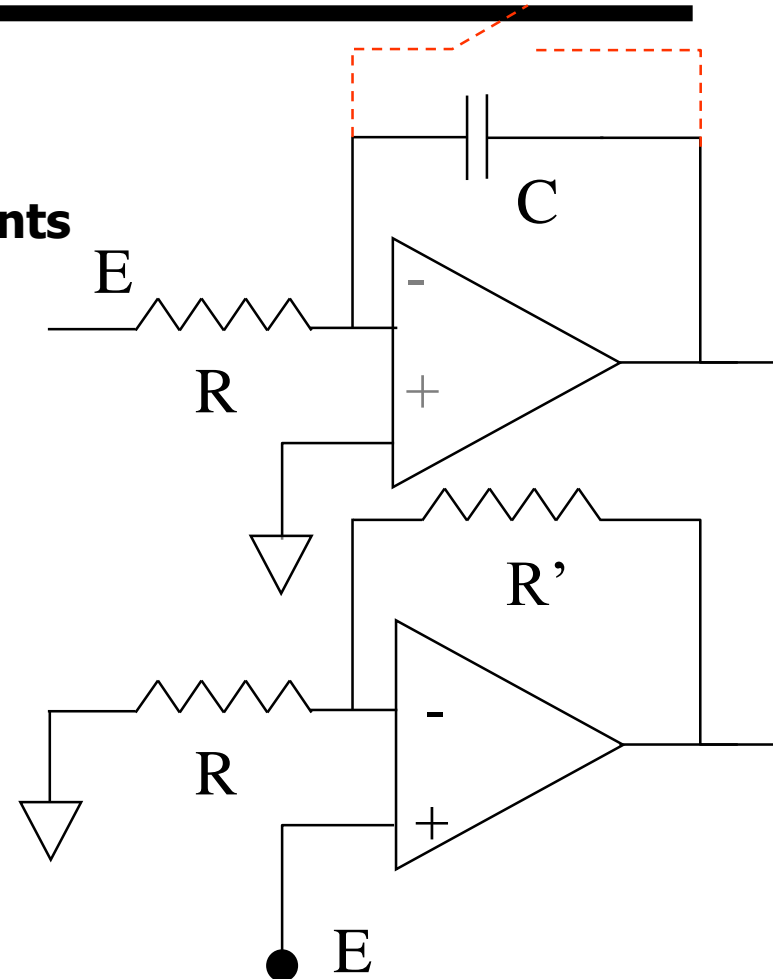
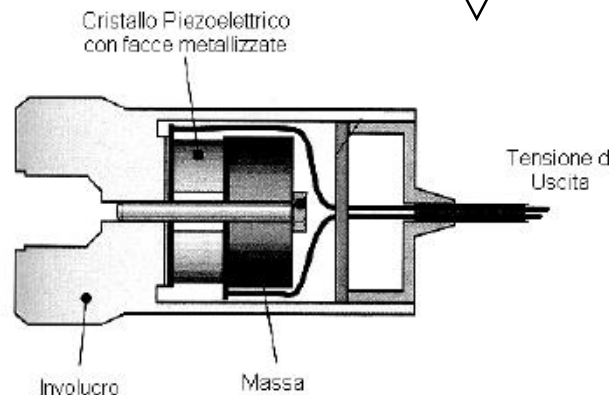

# MEMS ACCELEROMETERS

---

- MEMSIC in MEMS technology = a system for measuring a movement made up with a silicon integrated circuit.
- MEMS (Micro-Electro-Mechanical-System) = ensemble of all those elements (sensors, actuators and electronic devices), carried out by means of a  $\mu$ integration process on a silicon layer.
- If used for measuring the acceleration the range is  $[\pm 1g \div \pm 100g]$ .
- Both dynamic (vibrations) and static (gravity) accelerations.
- Resolution  $< mg$ , at least at very low frequencies.
- Available in hermetically sealed with low thickness (2 mm).
- Temperature range  $[-40^{\circ} \div +105^{\circ}]$ .

# MEMS ACC.: HOW THEY WORK

---

- Based on the heat transfer due to spontaneous convection. It measures the change in the heat distribution due to acceleration.
- MEMSIC accelerometers are functionally equivalent to those mass-spring, but in this case the prove mass is a gas bubble.
- Great advantages compared to traditional solid mass:
  - The device does not feature dead areas due to friction or other passive sources that spread energy like in other traditional transducers;
  - It resists to the shock up to 50000 g with a significant reduction of damages and less wastes during assembling.
- Convection: a thin bubble of heated gas “moves” due to external forces (accelerations, decelerations, gravity, vibrations, etc ...).
- Cool air has a great density than hot one. If this one is located close to a heat source every movement or variation in the gravity makes the more dense cool air to push the hot away far from the center of the cavity.

# MEMS ACC.: HOW THEY WORK

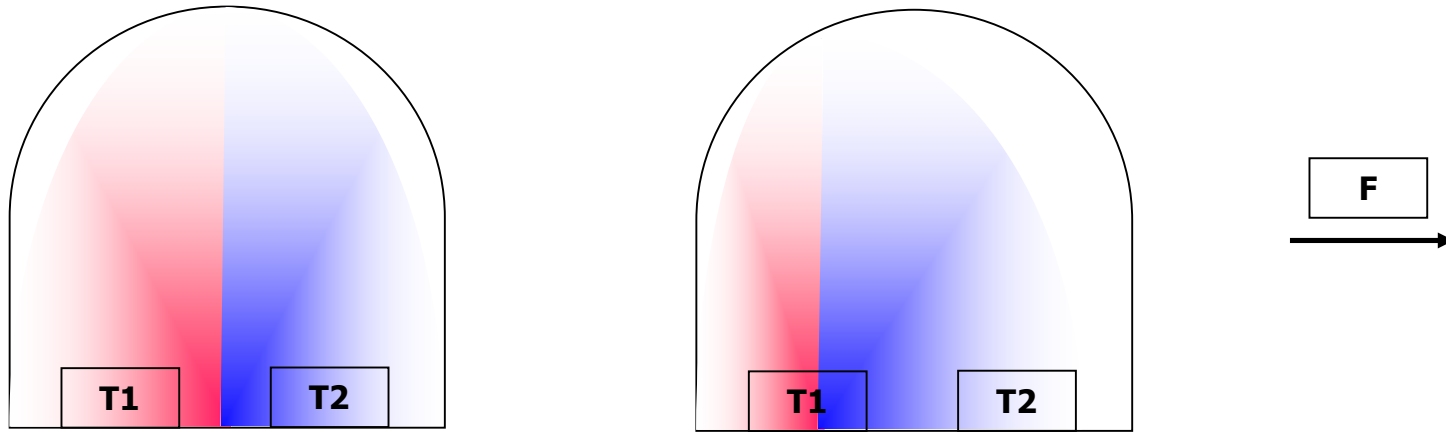

- By applying an external force (ex. acceleration) the cool air more dense compresses the warmed air. The internal symmetry changes in the same direction.
- In turn this phenomenon brings to a temperature difference in the air close to the two sensible elements (temperature sensors).
- By amplifying this difference the obtained electronic signal is proportional to the applied force and to its direction. This direction may be both horizontal (acceleration or deceleration) and vertical (inclinations or *tilt*).



# MEMS ACC.: HOW THEY WORK

- A heat source, centered in the silicon chip, is located internally to a cavity.
- Two thermopiles (groups of thermocouples) in aluminum/polysilicon, are at the same distance on the two sides of the heat source.

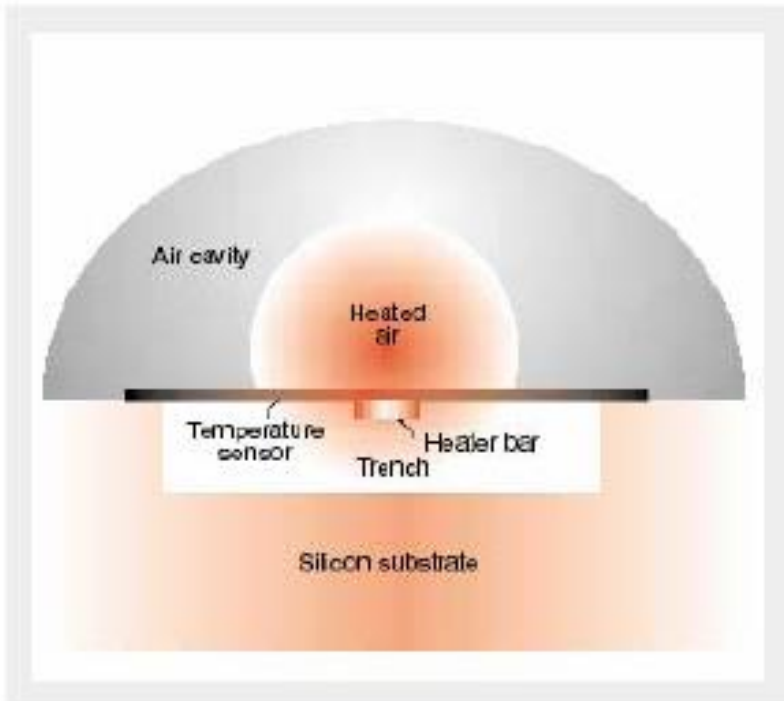
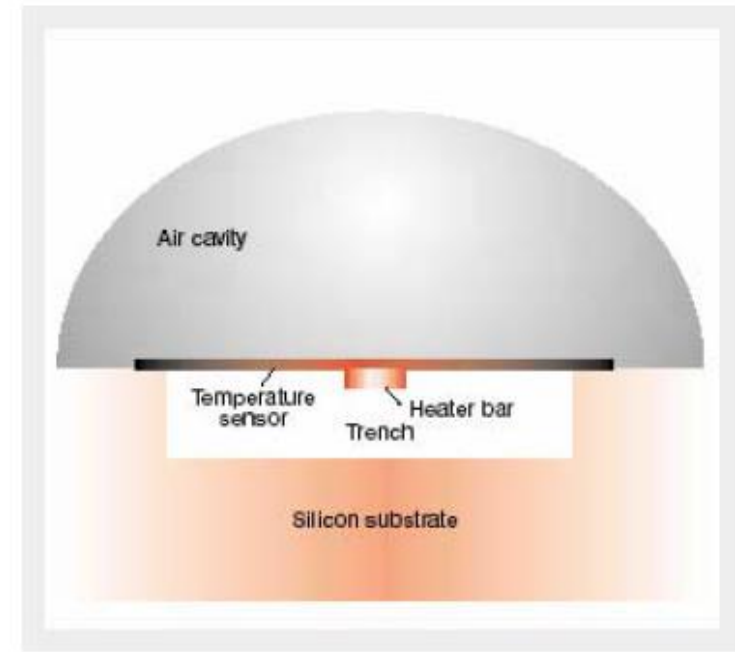

- When the acceleration is zero the temperature is the same on the two thermopiles so as they have the same output voltage (measured voltage zero).

# MEMS ACC.: HOW THEY WORK

- A strong acceleration will perturb the temperature profile due to the free convection of the heat making it asymmetric.
- The temperature, and therefore the voltage output, will be different in the two thermopiles.
- The asymmetric temperature profile corresponds to the moving direction
- The density of the cool air (greater) pushes the heated bubble determining a difference in the temperatures measured by the two thermopiles.
- This influences the resistances of the thermocouples in the thermopiles and this inhomogeneity produces an output proportional to the acceleration.
- In the figure the bubble displacement is shown towards right, due to the application of a deceleration or a variation of the gravity force.

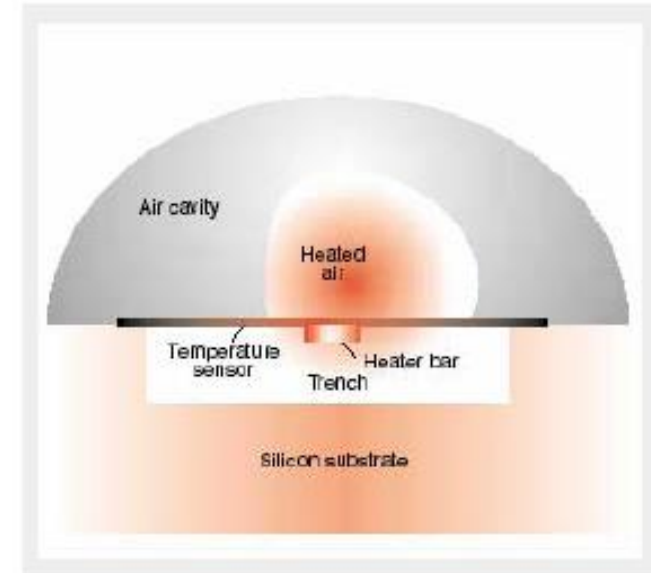

# MEMS ACC.: HOW THEY WORK, SUMMARY

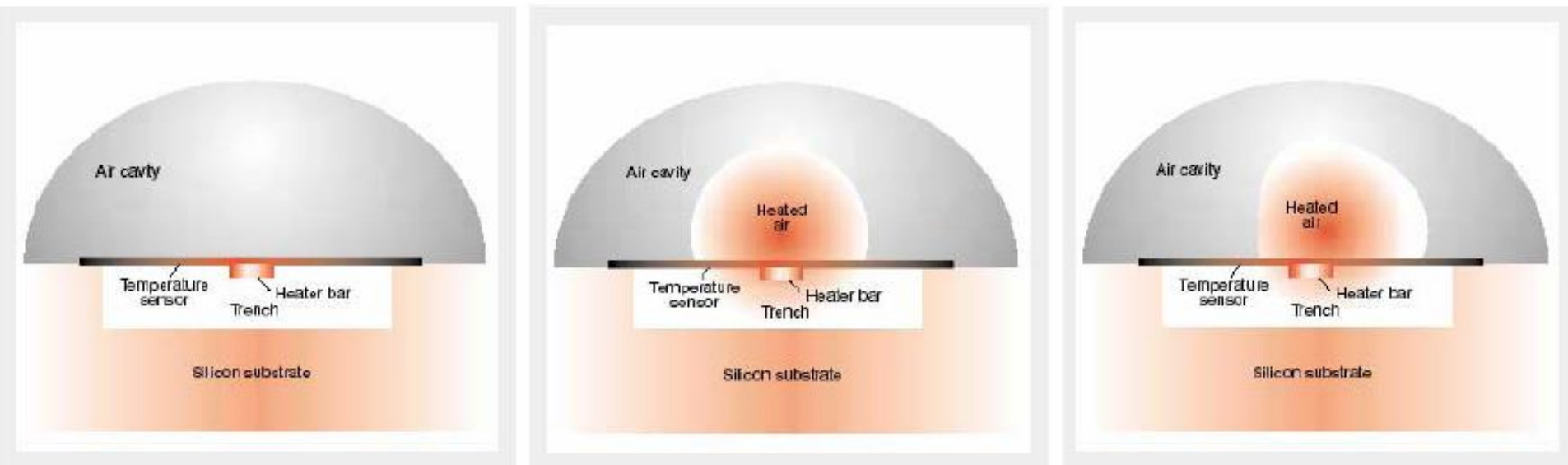

**Not fueled**

**Fueled stopped**

**Fueled with  
acceleration**

# MEMS ACC.: GENERAL SUMMARY

---

Micro mechanical systems very promising for consumers electronics and sensors.

Video games console, digital images stabilizers, fall arrester sensors.

Miniaturizability  $\Rightarrow$  wearability.

Low costs  $\Rightarrow$  mass-market

Critical issues:

*automotive:*, shock resistance, temperature range, size

*consumer:* low power, shock resistance, reliability, size

Manufacturers:

Texas Instruments, Hewlett Packard, Bosch, ST Microelectronics, Freescale, Seiko, Lexmark.

# FORCE AND PRESSURES MEASUREMENTS: STRAIN GAGE

---

- **Strain gage: 'strips' applied to areas undergoing to deformations**
- **Still the piezo-resistive effect: a R subject to deformations changes its value**

$$R = \rho \frac{L}{A} \quad \text{A } \Delta L \text{ stretching causes a resistance variation } \Delta R$$

$$\Delta R = \frac{\rho}{A} \Delta L + \frac{L}{A} \Delta \rho - \frac{\rho L}{A^2} \Delta A$$

- If the length augments both the resistance and the resistivity augment and the section diminishes (at fixed volume)

**Let's define:**

$$g = \frac{\frac{dR}{R}}{\frac{dL}{L}} \quad \text{gage factor}$$

# FORCE AND PRESSURES MEASUREMENTS: STRAIN GAGE

Let's multiply the previous expression by  $\frac{L}{RdL}$

$$g = \frac{L\rho}{AR} + \frac{L^2}{AR} \frac{\Delta\rho}{\Delta L} - \frac{L}{A} \frac{\Delta A}{\Delta L} = 1 + \frac{\frac{d\rho}{\rho}}{\frac{dL}{L}} - \frac{\frac{dA}{A}}{\frac{dL}{L}}$$

- An elongation makes the area A to diminish, not the volume

$$V = AL \quad \text{se } \Delta L > 0 \quad \Rightarrow \quad \Delta(AL) \geq 0$$

$$LdA + AdL \geq 0 \quad (\text{derivation by parts})$$

$$-\alpha = \frac{\frac{dA}{A}}{\frac{dL}{L}} < 0 \quad \text{traction implies minor section}$$

# FORCE AND PRESSURES MEASUREMENTS: STRAIN GAGE

---

$$g = 1 + \frac{\frac{d\rho}{\rho}}{\frac{dL}{L}} + \alpha \quad 0 < \alpha < 1$$

- The most important term is the second one. In metals  $g$  is between 0 and 12, for semiconductors even between 100 and 200 (in this case, however, problems arise about the sensibility to the temperature).
- Used in couple of sensors (with Wheatstone bridge conditioning circuits) to compensate homologous resistance variations due to environmental factors and at the same time to highlight differential variations.
- Mounted on an elastic support not exerting opposition to the deformation.
- Horizontal and vertical deformations, forces, torques, torsions are measured.

# FORCE AND PRESSURES MEASUREMENTS: STRAIN GAGE

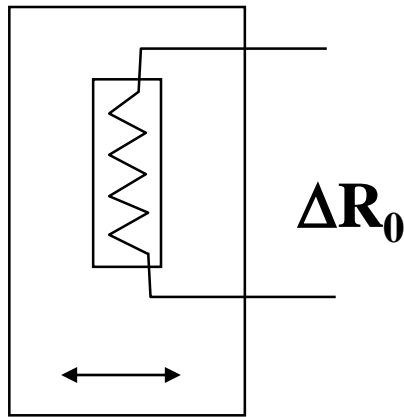

**Horizontal deformation**

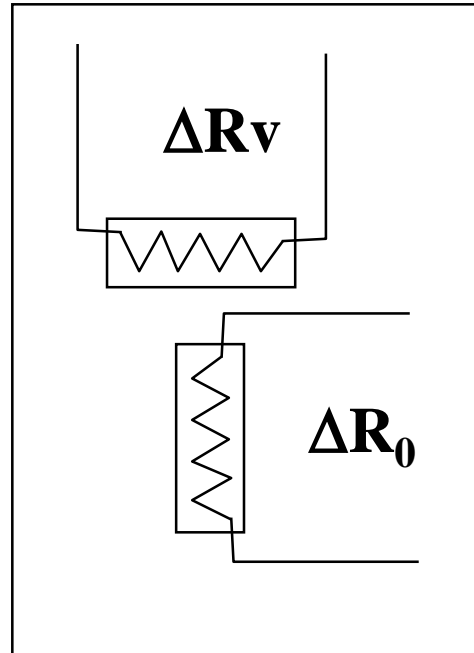

**Deformation measurement**

Horizontal deformation + vertical deformation

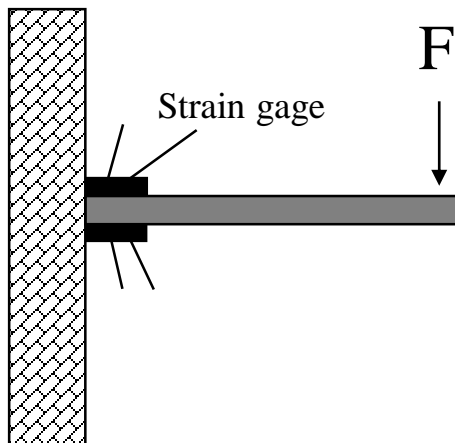

**Force measurements:** two strain gages with two deformations in stretching and shrinking. With a bridge circuit the difference in the variation of the resistors is highlighted



# FORCE AND PRESSURES MEASUREMENTS: STRAIN GAGE

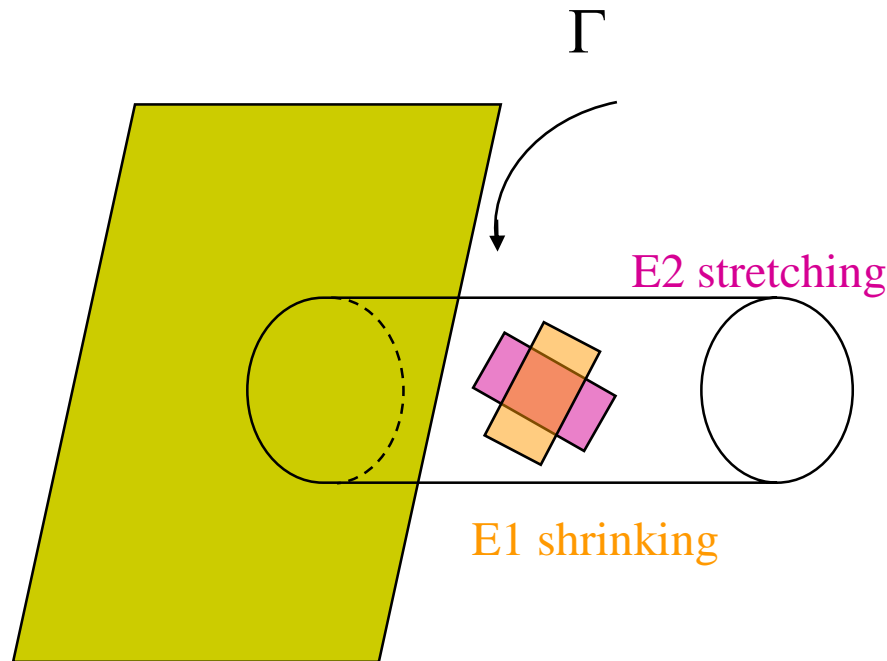

## Torsion of a shaft measurement:

- The two strain gage measure 2 deformations due to stretching and shrinking.
- The provided values are equal but opposite in sign.
- With a Wheatstone bridge the difference in the variation of R is highlighted so increasing the sensibility of the transducer and compensating the effect of the temperature.

# TEMPERATURE TRANSDUCERS

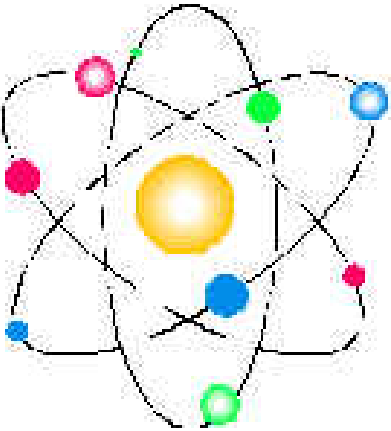

**Seebeck effect = due to thermal agitation (thermo-ionic effect), free charges (electrons in metals, holes in semiconductors) can escape from the conduction band where they usually are.**

**If a material features extremities at different temperatures the charges diffuse from the «hot» to the «cool» one (but also viceversa) till the a thermal equilibrium is reached.**

**If the difference between the temperature between the terminals is constant the flux is continuous. However the diffusion velocity of the charges is related to their energy and thus to their temperature (Richardson law).**

**Therefore a charge density is born at one of the extremities greater than in the other one and this creates an electric field.**

**The circling of the field on the conductive material provides a voltage  $\propto$  temperature variation.**

$$V = \int E dl = \int k \text{ grad}(T) dl$$



# THERMOCOUPLES

The relationship between the generated voltage and the temperature variation depends on the type of material (copper, constantan, nickel-cromium).

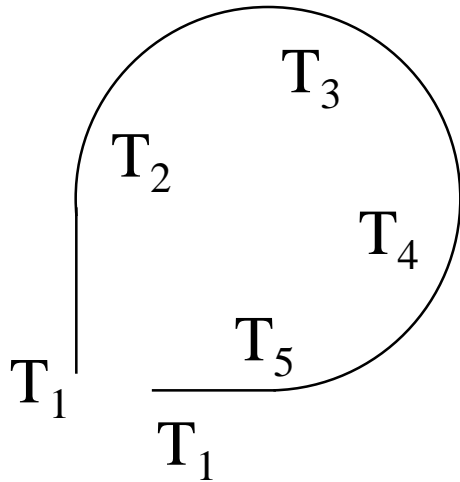

**A conductor close on itself does not provide any voltage even though  $dV/dx$  are present throughout the conductor.**

**Where a  $\Delta T > 0$  is present the electric field is oriented at the opposite with respect to where  $\Delta T < 0 \Rightarrow$  the overall field is null.**

**Now if we use different materials, in presence of temperature gradients ( $T_2 > T_1$ ), different electric field arise and electromotive forces that do not compensate.**

**The consequent voltage can be related to the temperature difference (proportional, first approximation).**

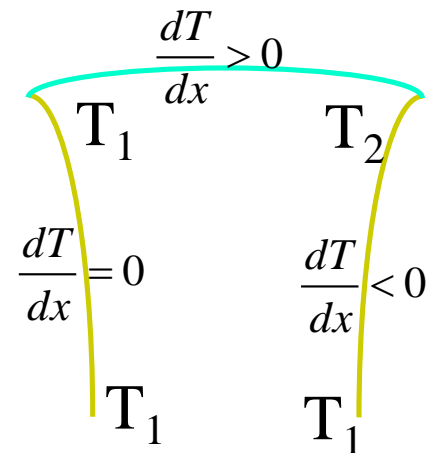

# THERMOCOUPLES

The real expression that relates  $V_{tc}$  and  $\Delta T$  is

$$V_{tc} = \alpha(T_2 - T_1) + \beta(T_2 - T_1)^2 + \dots$$

In practice the transducer works only in the linearity zone. As an alternative look up table are implemented within the microprocessor where the  $\Delta T$  correspondence with the measured voltage is provided.

However often it is important to obtain the absolute temperature of an environment: thus, one of the 2 junctions must be set at a known temperature (ex. a tub with ice and water at  $0^\circ\text{C}$  with another reference temperature transducer).

This technique is called «cool joint compensation».

Range ( $-200^\circ\text{C}$ ,  $2000^\circ\text{C}$ ); sensibility  $50\mu\text{V}/^\circ\text{C}$

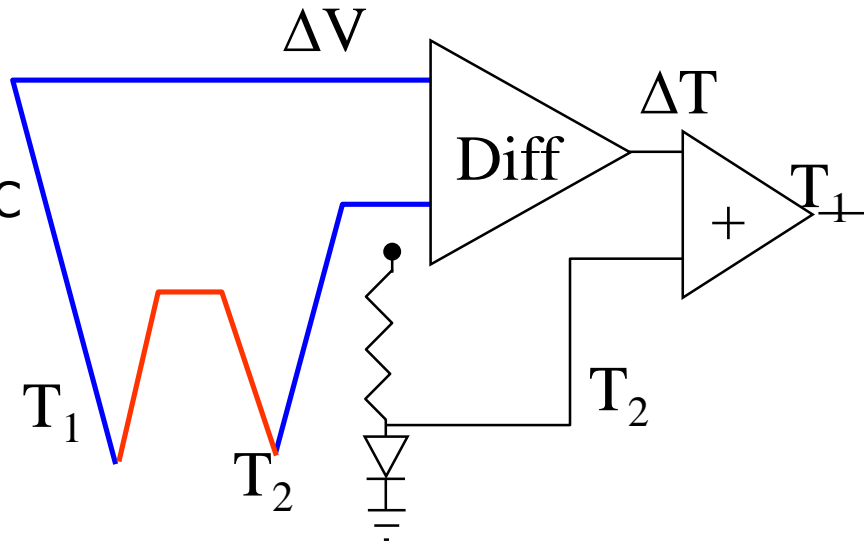
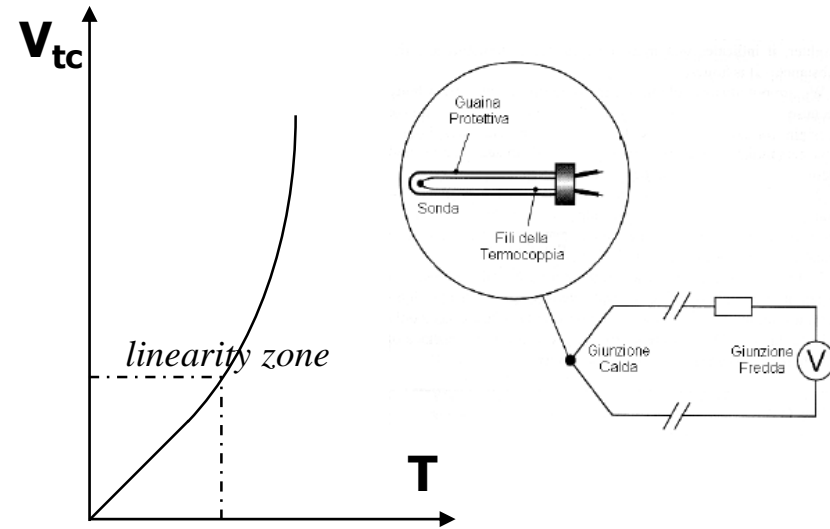

# THERMOPILES

Thermocouples are used to measure temperature variations  $\approx (100^{\circ}\text{C}-200^{\circ}\text{C})$

Thermoresistors instead are used to keep a reference temperature

Weak output voltages ( $5\div 50 \mu\text{V}/^{\circ}\text{C}$ )  $\Rightarrow$  amplification and short connections

As an alternative a series of thermocouples  $\Rightarrow$  THERMOPILES

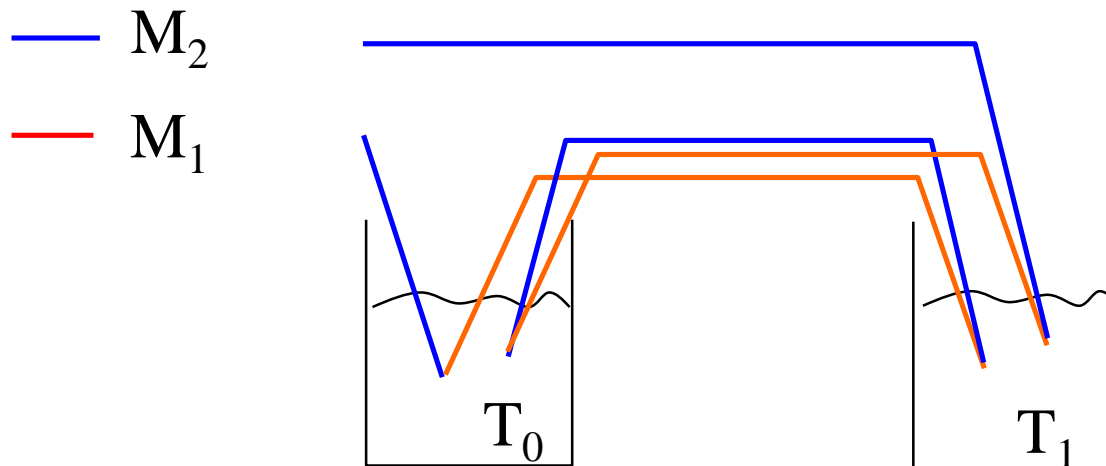

Ex. 5 wire tracts with two 2 junctions at different temperatures, with a proportional voltage

$$V_t = 2\alpha (T_1 - T_0)$$

Limited by connection complexity (not many junctions are possible)

Low impedance circuits with strong currents (1-2 A)

The transducer deprives the physical process of a small amount of energy

# THERMORESISTANCES AND THERMISTORS

---

Here the *temperature – resistance* conversion is exploited: in thermo-resistances, depending on the used metal, the temperature variation can affect the electrons average path (reduces) so as modifying the resistance of a conductive material.

If semiconductors are used (thermistors) charge modulation must be taken into account (they augment if T is increased), that prevail in the R determination.

These effects are present in the two material classes called: PTC e NTC

---

## PTC (positive temperature coefficient)

**Collisions between free electrons and crystal lattice:  $>T$  ,  $>$ resistance**

$$R = R_0 (1 + \alpha(T - T_0)) \quad \text{per } T = T_0 \quad R = R_0 \quad \alpha = dR / (R_0 dT)$$

- $\alpha$  positive and dependent on T and on the material (for Platinum at 0°C is 0.0038)
- it is also possible to write  $R = R_0 (1 + \alpha(T - T_{k0})) = R_0 (1 + (T - T_{k0}) / T_{k0}) = R_0 (T / T_{k0})$  linear relation between the absolute T if  $\alpha = 1 / T_{k0}$  (Kelvin) => thermometer
- PTC linear in typical temperature ranges (PT100 works between 0 and 100°)
- good sensibility if compared to, for example, strain gages

# THERMORESISTANCES AND THERMISTORS

## NTC (negative temperature coefficient)

- dependency on the free moving charges
- R diminishes if T augments ( $\sim$  Steinhart-Hart law)
- semiconductors are typically used

$$R = R_0 e^{-B \left( \frac{1}{T_0} - \frac{1}{T} \right)}$$

$$\text{Sensibility} \quad \alpha = -\frac{B}{T^2} e^{-B \left( \frac{1}{T_0} - \frac{1}{T} \right)}$$

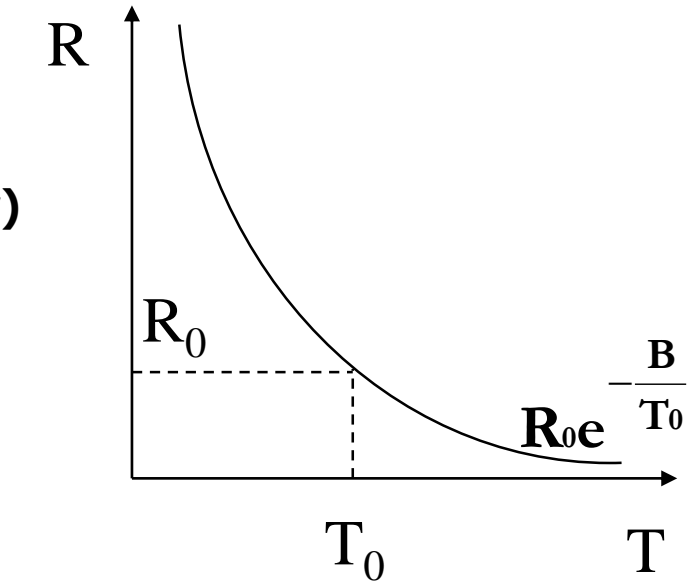

$$\alpha_{T_0} = -\frac{B}{T_0^2}$$

$$B \approx 1000-2000 \quad \alpha_{\text{NTC}} \gg \alpha_{\text{PTC}}$$

**High sensibility dependent on the temperature**

**Used for keeping reference temperatures controlled (thermostat)**

# THERMORESISTANCES AND THERMISTORS

---

**NTC are very often employed to monitor continuously the temperature.**

**These sensors feature a sensibility very higher than thermo-resistances without any further electronic circuits since their SNR is very high (due to the high sensibility) and the parasite effect of the connection cables can be neglected.**

**Conversely in case of large variations in temperature, NTC thermistors are greatly un-linear, therefore it is necessary correction circuits, or Look-Up-Tables for linearization or to perform suitable numerical interpolations trough microprocessor running code.**

**PTC sensors work in a more reduced interval and are typically used to protect devices and circuits by overloads and thermal shocks due to over-heating. In this case, thanks to the high gain and to their threshold answer, they are provided with a logic output circuit to signal the exceeding of a predefined temperature.**

**PTCs work as detectors of thermal threshold coupled with suitable calibrated comparators.**



# INTEGRATED TEMPERATURE TRANSDUCERS

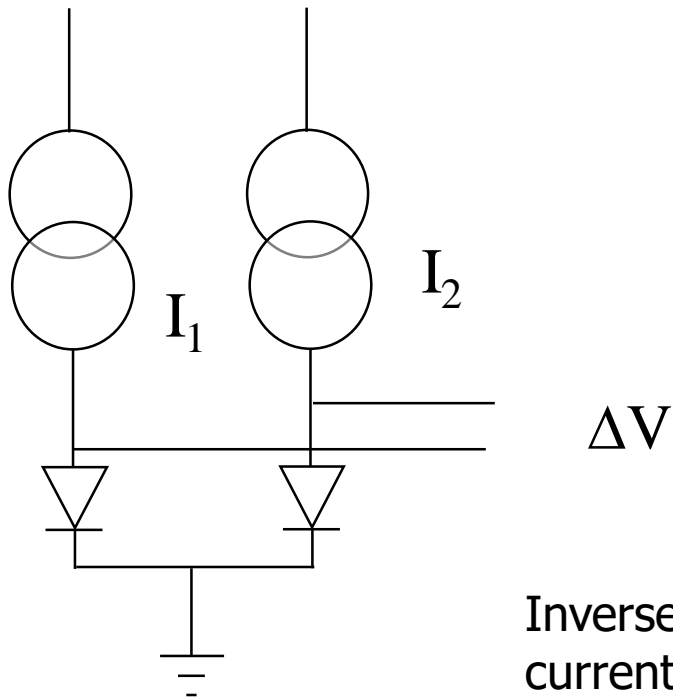

Inverse polarization current in the diode

$$\Delta V = \frac{KT}{e} \ln \frac{I_2}{I_1} \quad \text{since}$$

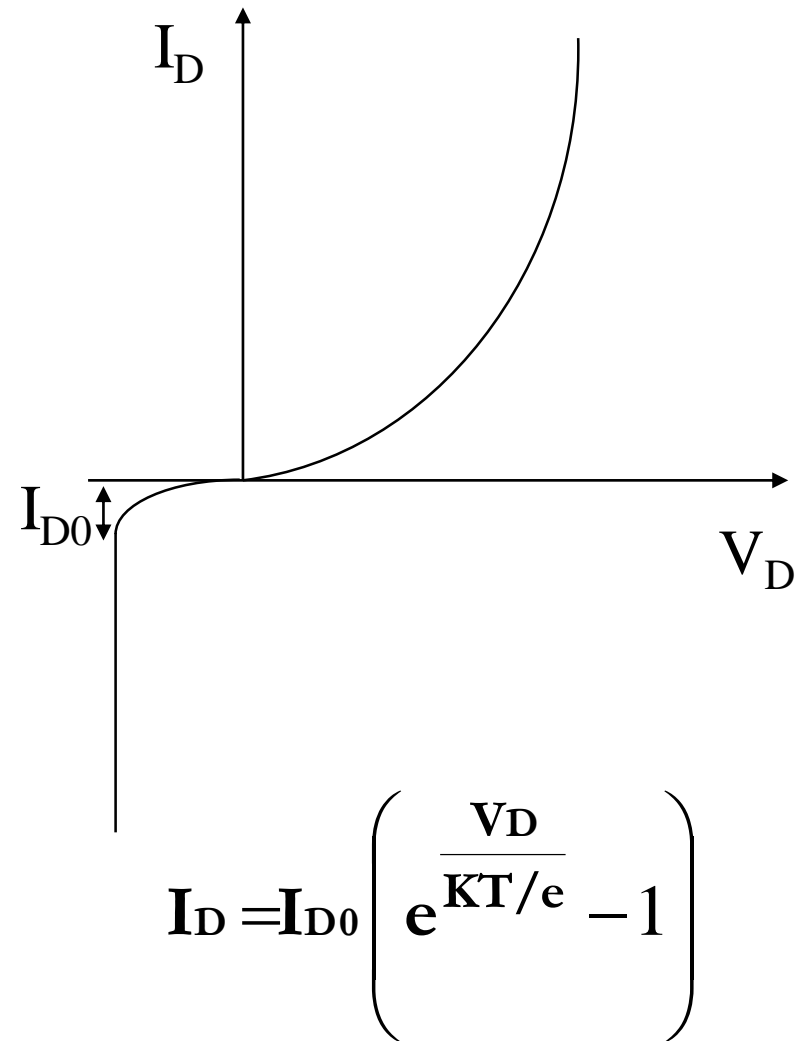

# PRESSURE TRANSDUCERS

They are based on the conversion of the pressure in the *deformation* of a foil mounted on a suitable «proof chamber».

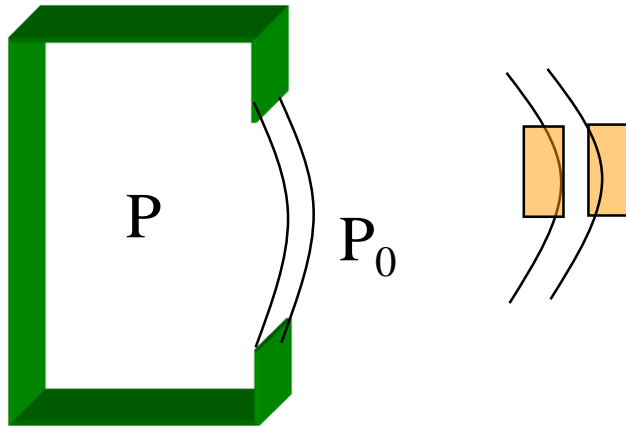

Two strain gages mounted in the center of one of the walls, measure opposite deformations  $\Rightarrow$  Wheatstone bridge

Calibration: a known pressure is applied to the system to determine the  $\propto$  coefficient between the pressure and the unitary deformation

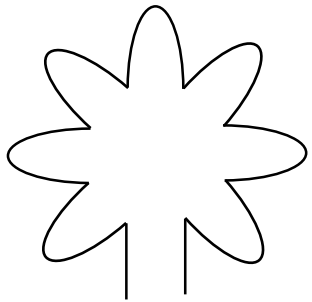

Daisy petal strain gages to measure spherical deformations

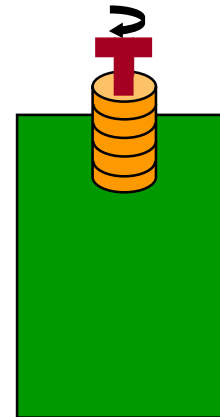

A transducer is screwed through filleting to the chamber into which the pressure must be measured

# PRESSURE TRANSDUCERS

In this case they are based on the conversion between the *displacement* of the foil mounted again in a suitable «proof chamber» and the pressure.

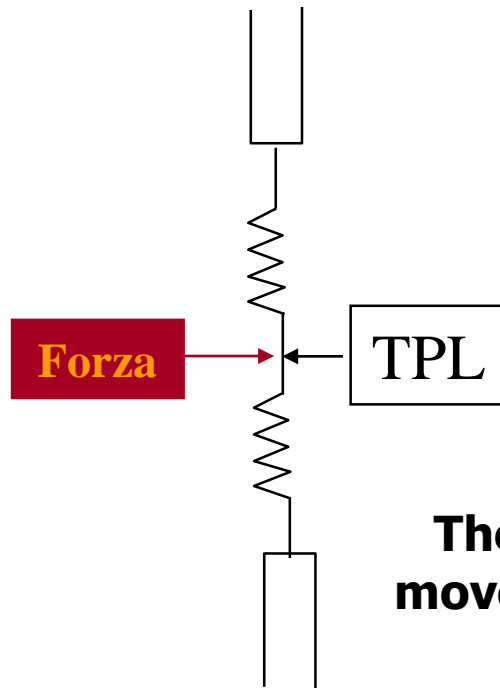

“bellows” foil  
oscillations of the foil  
top view

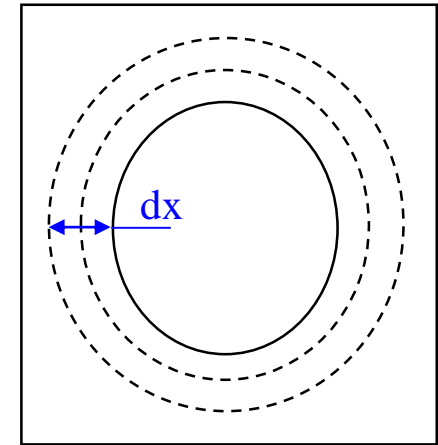

The foil can also be seen like a spring that resists to the movement with a elasticity coefficient  $k$  and a section  $A$  on which the push is exerted

$$k = \frac{F}{dx}$$

$$dx = \frac{A}{k} (p - p_0)$$

# PRESSURE TRANSDUCERS

## BOURDON TUBE

Elliptical section wound so as to make a spiral.

The elliptical section if undergone a pressure tends to become circular (unfolding, blue arrow).

If instead the pressure is negative the rotation is in the opposite direction (folding, red arrow).

An angular transducer is necessary to measure the rotation.

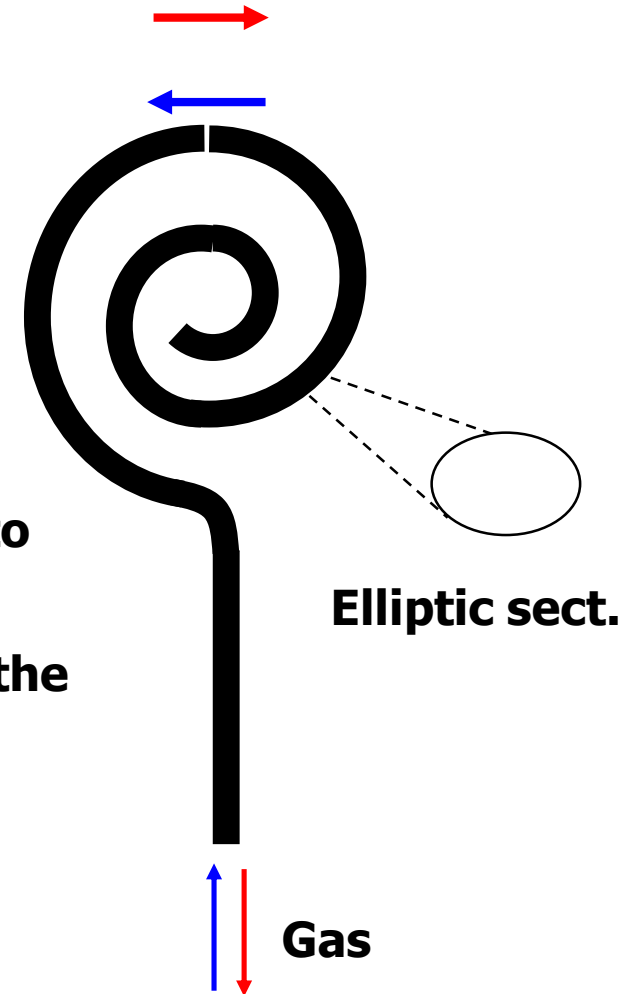

# FLOW-METERS

- Within a tube into which a stream flows a *mass flow rate*  $F_m$  and a *volume flow rate*  $F_v$  (constant volume)
- $F_m = dm/dt =$  infinitesimal quantity of mass of fluid that flows in a time  $dt$  in the tube section.
- $F_v = dv/dt =$  infinitesimal quantity of mass of fluid that flows in a time  $dt$  in the tube section.
- $F_m = \delta F_v$        $\delta = dm/dv$
- Notice that for the gas the volume changes depending on the pressure (> compressibility)
- The easiest measurement is  $F_v$  that is obtained through a velocity
- $F_v = A v_m$        $v_m =$  average vel.  
media       $A =$  effective sect.
- If the flow meter is coupled with a pressure transducer (from which the density can be achieved by means of the Bernoulli law), we have a mass flow-meter.
- We only deal with volumetric flow-meters (by hypothesis we work at constant volume)

# TURBO FLOW METER

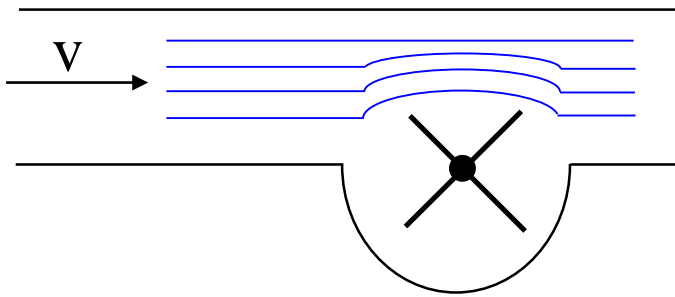

- $f = \alpha v_m$        $v_m = \text{average velocity}$   
                                  $\alpha = \text{turbine charact.}$   
                                  $f = \text{rotation frequency}$
- We can guess that  $f = \beta F_v$  so  
since  $F_v = A v_m$

$$\beta = \alpha/A$$

- $\beta$  dimensions are 1/vol.
- By measuring fluid quantity that moves with the turbine we obtain  $\beta$ ;  $f$  can be measured with a dynamo.

## Problems:

- the turbine can disturb the flow so altering the measurement and this depend on the viscosity and density of the fluid
- Viscosity and density affect also  $\beta$

# ELECTROMAGNETIC FLOWMETER

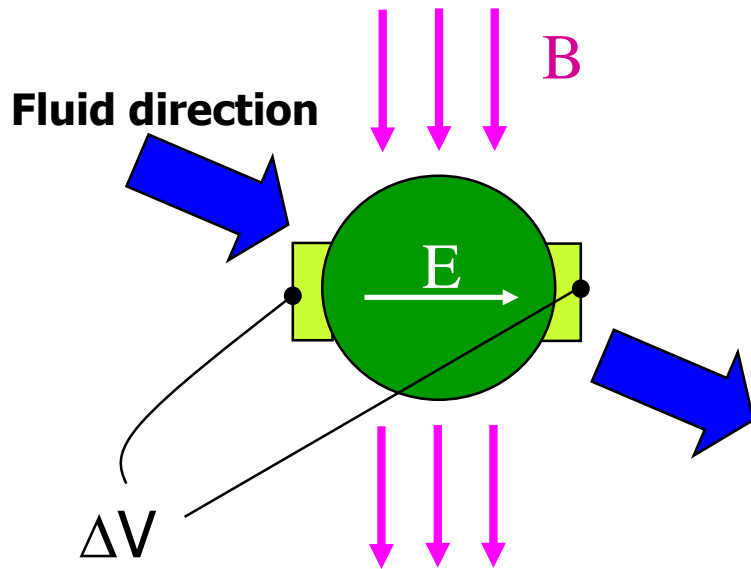

- A fluid with a good conductivity
- Solution that does not disturb the phenomenon to be measured
- Due to the B field applied an electric one arises  $E = v \times B$  (Lorentz law)
- The metal plaques measure the  $\Delta V$  developed in the fluid (conductive) by the electric field

**Hypothesis: uniform velocity distribution (even in case of turbulent flow)**

**Uniform B field  $\Rightarrow$  the same for the field E**

**The situation can be associated to a capacitor**

$$\Delta V = Ed = Bdv_m$$

**d=diameter,  $v_m$ =average vel.**

$$F_v = Av_m = \pi d^2 v_m / 4$$

$$\Delta V = 4B F_v / \pi d$$

# ELECTROMAGNETIC FLOWMETER

---

- **Considering the average velocity is a strong approximation (true only if the velocity distribution is cylindrical).**
- **The transducer produces a current and this deprives energy to the flow (slightly slower than if not measured).**
- **Need for accurate electrodes to avoid contact voltages that alter the measure. It is possible to avoid this by modulating the field  $B$  using AC power supply. The eventual contact voltage is easily cancelled.**
- **The output is in phase or counterphase with the power supply depending on the direction of the fluid. A synchronous rectifier is required.**
- **Useful pattern since without mechanical parts (like as the turbine)**



# ULTRASOUND FLOWMETER

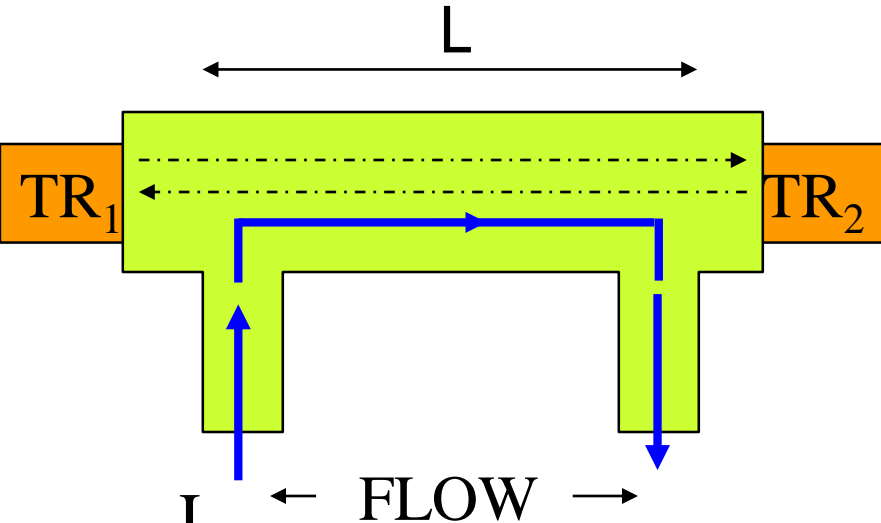

**Ultrasound propagation chamber with generators/receivers on two sides**

**The emission of a US beam from TR<sub>1</sub> is perceived by TR<sub>2</sub> in a time t<sub>12</sub>**

$$t_{12} = \frac{L}{c + v}$$

c + v

ULTRASOUND + LIQUID VELOCITIES

$$t_{21} = \frac{L}{c - v}$$

L chamber length

$$t_{21} - t_{12} = L \left[ \frac{1}{c - v} - \frac{1}{c + v} \right] = \frac{2vL}{c^2 - v^2} \cong \frac{2vL}{c^2}$$

where  $c \gg v$

# VENTURI TUBE (VENTURIMETER)

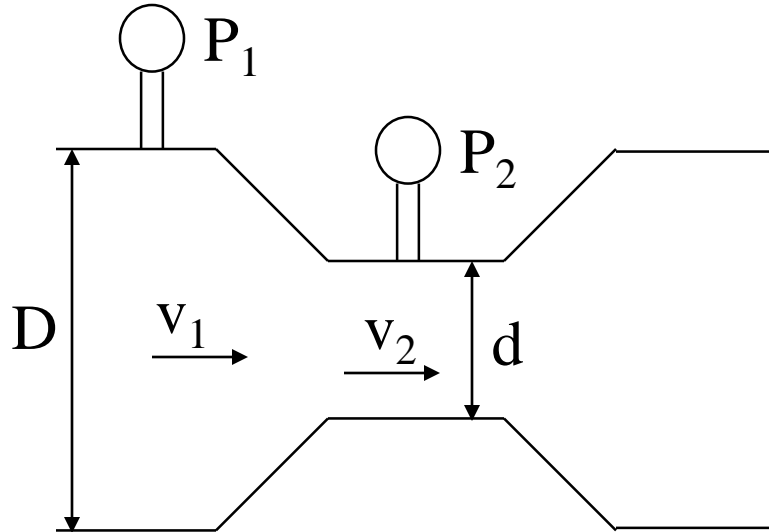

The bottleneck makes the velocity of the liquid to augment if the flow can be considered constant.

If the friction is neglected, the kinetic energy increases and the potential one diminishes

Bernoulli law:  $\rho v^2/2 + p + \rho gh = \text{const.}$

$$\frac{\rho v_1^2}{2} + p_1 = \frac{\rho v_2^2}{2} + p_2$$

$$\text{but } F = vA = v_1 \frac{\pi}{4} D^2 = v_2 \frac{\pi}{4} d^2$$

$$p_1 - p_2 = \frac{16 \rho F^2}{2\pi^2} \left[ \frac{1}{d^4} - \frac{1}{D^4} \right]$$

If we can consider the density constant

**The pressure diminishes in the bottleneck and this is only partially recovered in the final enlargement of the tube. Indeed we can have pressure drops due to the presence of vortices and friction/viscosity effects. For this reason,  $P_2$  is measured at the center of the bottleneck.**

# LEVEL-METERS

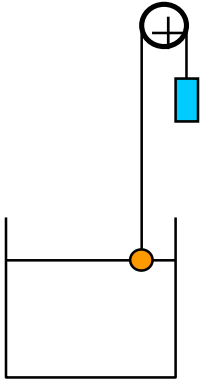

**A first solution can be given by a float element connected to a pulley with an angular position transducer.**

**The wire/rope must be always tensed and the weight constant.**

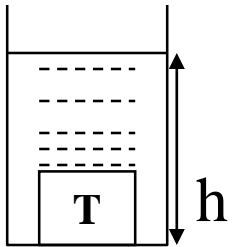

**A second option exploits a ultrasound generator on the bottom of tub: the US beam is reflected by the water edge and the echo is received after a time**

$$t=2h/c$$

**$c$  can depend on the liquid temperature. To break out from this, an intermediate path can be introduced with a fixed obstacle located at a known height. The obstacle reflects part of the US beam so as**

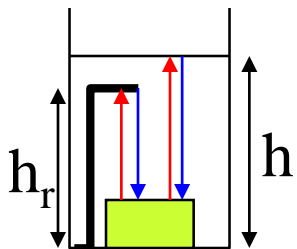

$$h=h_r t/t_r$$

# RESISTIVE AND CAPACITIVE LEVEL-METERS

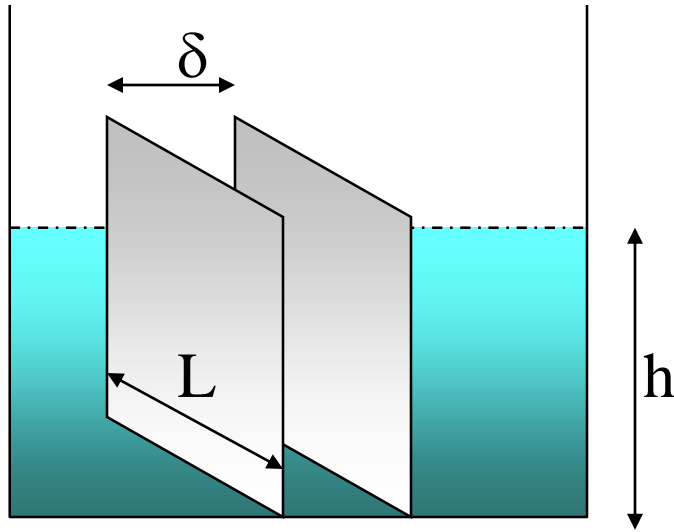

**2 armors merged in a container to allow resistive or capacitive measurements**

**If a conductive liquid is used the resistance measure is performed at low-medium frequencies while at high ones a capacitive one is performed so as to neglect the resistive contribute in parallel to the capacitor.**

RESISTIVE MEASUREMENT

$$R = \frac{\delta \rho}{A} = \frac{\delta \rho}{Lh} \quad A = Lh \text{ (merged surface)}$$

CAPACITIVE MEASUREMENT

$$C = \epsilon_0 \frac{A_1}{\delta} + \epsilon_0 \epsilon_r \frac{A}{\delta} \quad A = Lh \quad A_1 = (H - h)L \quad (H \text{ electrodes height})$$

$$C = \epsilon_0 \frac{LH}{\delta} + \epsilon_0 \frac{(\epsilon_r - 1)hL}{\delta}$$

# ACIDITY MEASUREMENT (PH-METER)

**Acid and basic solutions dissociate in water in positive and negative ions. Mainly  $H^+$  ions if acid,  $OH^-$  ions otherwise.**

**Water itself undergoes the same phenomenon but it is conventionally considered electrically balanced with a  $H^+$  ions concentration equal to 1 every 10 million molecules ( $10^{-7}$ ).**

**If an acid substance is introduced the quantity of  $H^+$  ions increases while the  $OH^-$  diminishes and viceversa if a basic substance is added.**

**$pH = -\log [H^+]$  is defined as the index that measures the acidity of a solution.**

**In case of neutral solution  $pH=7$ , if it is basic  $pH=14$ , if acid  $pH=0$ .**



**A pH-meter is a scientific instrument made of a recipient with two electrodes of which one is merged in reference buffer solution.**

**The measurement corresponds to the  $\Delta V$  due to the surface contact between the two electrodes and the liquids (buffer solution + substance under analysis). The electrodes provide a potential constant for the reference solution and depending on the ion concentration for the analyzed substance**

# ACIDITY MEASUREMENT (PH-METER)

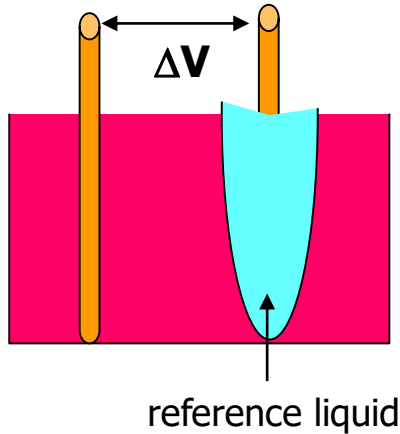

**It is possible to evaluate the ion concentration through this expression:**

$$\Delta V = E_0 - 0.0591 \log [H^+]$$

**The obtained voltage is small, to be amplified and enough accurate.**

**During instrument calibration a acid substance at first and then a basic one can be considered.**

**This causes a very abrupt variation in the pH and therefore in the measurement with however oscillations around the equilibrium state with possible stability problems (like as a high frequency variation would happen).**

**If however enough large tub are used the time needed for the pH variation will be greater since it will depend on the  $H^+$  ions diffusion.**

**The equilibrium reaction will be slower with less instability risks.**

**The system is sensible to the temperature (often it is associated to a transducer).**

**The conditioning network is an amplification stage that provides also the necessary decoupling from the remaining part of the circuit (since the electrodes feature high output impedance).**